

NTC Thermistors

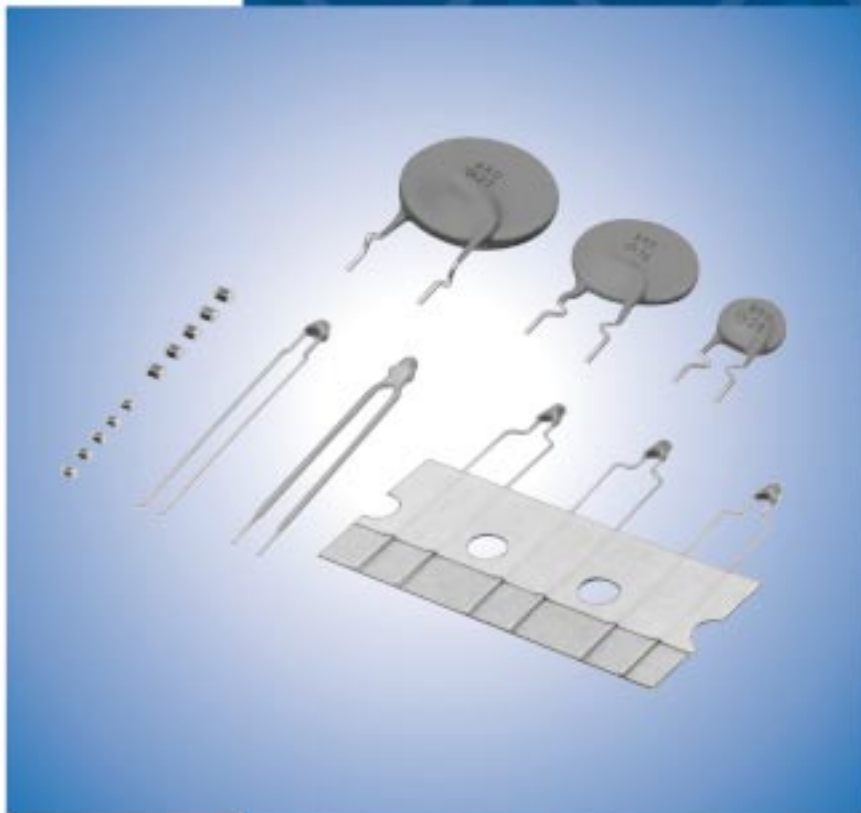

muRata

*Innovator
in Electronics*

Murata
Manufacturing Co., Ltd.

Cat.No.R44E-8

CONTENTS

Part Numbering	_____	2
Basic Characteristics	_____	4
1 for Temperature Compensation 0201 (0603) Size	_____	5
2 for Temperature Compensation 0402 (1005) Size	_____	6
3 for Temperature Compensation 0603 (1608) Size	_____	8
4 for Temperature Compensation 0805 (2012) Size	_____	10
for Temperature Compensation Temperature Characteristics (Reference Value)	_____	12
Chip Type ⚠Caution/Notice	_____	16
Chip Type Package	_____	19
5 for Temperature Sensor Resin Coated Radial Lead Type	_____	22
● for Temperature Sensor Temperature Characteristics (Reference Value)	_____	24
● for Temperature Sensor Lead Type ⚠Caution/Notice	_____	25
● for Temperature Sensor Lead Type NTSA/NTSD Series Package	_____	27
6 for Inrush Current Suppression Lead Type	_____	28
● Current-R Ratio (RT/R25) / Current-Temperature Characteristics (Typical)	_____	30
● for Inrush Current Suppression Lead Type ⚠Caution / Notice	_____	34
● for Inrush Current Suppression Lead Type Package	_____	36

1

2

3

4

5

6

● Part Numbering

NTC Thermistors for Temperature Compensation Chip Type

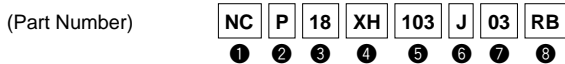

① Product ID

Product ID	
NC	NTC Thermistors Chip Type

② Series

Code	Series
P	Plated Termination Series

③ Dimensions (L×W)

Code	Dimensions (L×W)	EIA
03	0.60×0.30mm	0201
15	1.00×0.50mm	0402
18	1.60×0.80mm	0603
21	2.00×1.25mm	0805

④ Temperature Characteristics

Code	Temperature Characteristics
WB	Nominal B-Constant 4050—4099K
WD	Nominal B-Constant 4150—4199K
WF	Nominal B-Constant 4250—4299K
WL	Nominal B-Constant 4450—4499K
WM	Nominal B-Constant 4500—4549K
XC	Nominal B-Constant 3100—3149K
XF	Nominal B-Constant 3250—3299K
XQ	Nominal B-Constant 3650—3699K
XH	Nominal B-Constant 3350—3399K
XM	Nominal B-Constant 3500—3549K
XV	Nominal B-Constant 3900—3949K
XW	Nominal B-Constant 3950—3999K

⑤ Resistance

Expressed by three figures. The unit is ohm (Ω). The first and second figures are significant digits, and the third figure expresses the number of zeros which follow the two figures. If there is a decimal point, it is expressed by the capital letter "R". In this case, all figures are significant digits.

Ex.)

Code	Resistance
102	1kΩ
103	10kΩ
104	100kΩ

⑥ Resistance Tolerance

Code	Resistance Tolerance
F	±1%
J	±5%
K	±10%

⑦ Individual Specifications

Structures and others are expressed by two figures.

Code	Individual Specifications
03	Standard Type
0S	Automobile Type

Please contact us for details.

⑧ Packaging

Code	Packaging
RA	Plastic Taping 4mm Pitch
RB	Paper Taping 4mm Pitch
RC	Paper Taping 2mm Pitch (10000 pcs.)
RL	Paper Taping 2mm Pitch (15000 pcs.)

NTC Thermistors for Temperature Sensor Lead Type

(Part Number)

NT	SA0	XH	103	F	E1	B0
----	-----	----	-----	---	----	----

① ② ③ ④ ⑤ ⑥ ⑦

① Product ID

Product ID	
NT	NTC Thermistors

② Series

Code	Series
SA0	for Temperature Sensors No Lead-coating Type
SD0	for Temperature Sensors Lead-coating Type
SS0	Temperature Sensors for Automotive Equipment

③ Temperature Characteristics

Code	Temperature Characteristics
WB	Nominal B-Constant 4050—4099K
WC	Nominal B-Constant 4100—4149K
WD	Nominal B-Constant 4150—4199K
WF	Nominal B-Constant 4250—4299K
XM	Nominal B-Constant 3500—3549K
XH	Nominal B-Constant 3350—3399K
XR	Nominal B-Constant 3700—3749K
XV	Nominal B-Constant 3900—3949K

④ Resistance

Expressed by three figures. The unit is ohm (Ω). The first and second figures are significant digits, and the third figure expresses the number of zeros which follow the two figures. If there is a decimal point, it is expressed by the capital letter "R". In this case, all figures are significant digits.

Ex.)

Code	Resistance
202	2k Ω
203	20k Ω

⑤ Resistance Tolerance

Code	Resistance Tolerance
E	$\pm 3\%$
F	$\pm 1\%$

⑥ Individual Specifications

A lead structure and other specifications are expressed by two digits.

Code	Individual Specifications
E1	Bulk
N6	Standard Taping

⑦ Packaging

Code	Packaging
A0	Ammo Pack
B0	Bulk

NTC Thermistors for Inrush Current Suppression

(Part Number)

NT	PA7	160	L	BM	B0
----	-----	-----	---	----	----

① ② ③ ④ ⑤ ⑥

① Product ID

Product ID	
NT	NTC Thermistors

② Series

Code	Series	Nominal Body Diameter
PA7	Inrush Current Suppression Lead Type	7mm
PA9		9mm
PAA		10mm
PAD		13mm
PAJ		18mm
PAN		22mm

③ Resistance

Expressed by three figures. The unit is ohm (Ω). The first and second figures are significant digits, and the third figure expresses the number of zeros which follow the two figures. If there is a decimal point, it is expressed by the capital letter "R". In this case, all figures are significant digits.

Ex.)

Code	Resistance
3R0	3 Ω
100	10 Ω

④ Resistance Tolerance

Code	Resistance Tolerance
L	$\pm 15\%$

⑤ Individual Specifications

A lead structure and other specifications are expressed by two capital letters.

Code	Individual Specifications	Body Diameter
DK	Standard Type	$\phi 18\text{mm}$, $\phi 22\text{mm}$
DN	Standard Type	$\phi 10\text{mm}$, $\phi 13\text{mm}$
BM	Standard Type	$\phi 7\text{mm}$, $\phi 9\text{mm}$

⑥ Packaging

Code	Packaging
A0	Ammo Pack
B0	Bulk

Basic Characteristics

Basic Characteristics

1. Zero-power Resistance of Thermistor : R

$$R=R_0 \exp B (1/T-1/T_0) \dots\dots\dots(1)$$

R : Resistance in ambient temperature T (K)
(K : absolute temperature)

R₀ : Resistance in ambient temperature T₀ (K)

B : B-constant of Thermistor

2. B-Constant

as (1) formula

$$B= \ell n (R/R_0) / (1/T-1/T_0) \dots\dots\dots(2)$$

3. Thermal Dissipation Constant

When electric power P (mW) is spent in ambient temperature T₁ and thermistor temperature rises T₂, there is a formula as follows

$$P=C (T_2-T_1) \dots\dots\dots(3)$$

C : Thermal dissipation constant (mW/°C)

Thermal dissipation constant is varied with dimensions, measurement conditions, etc.

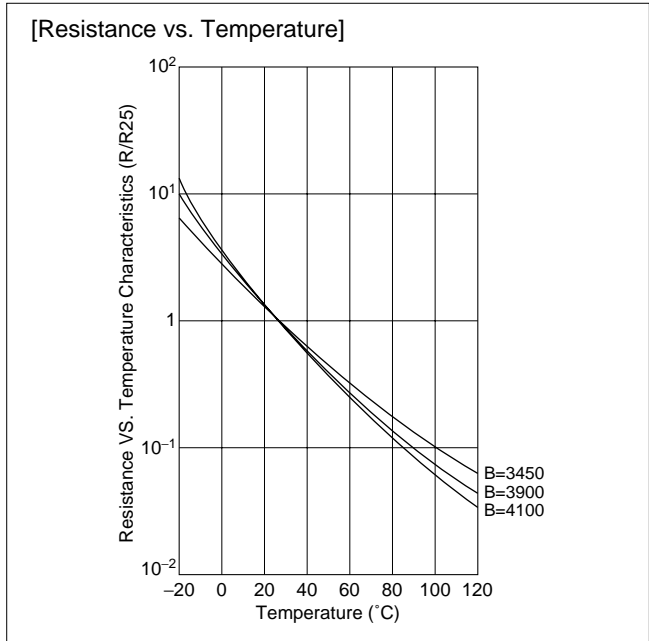

4. Thermal Time Constant

Period in which Thermistor's temperature will change 63.2% of its temperature difference from ambient temperature T₀ (°C) to T₁ (°C).

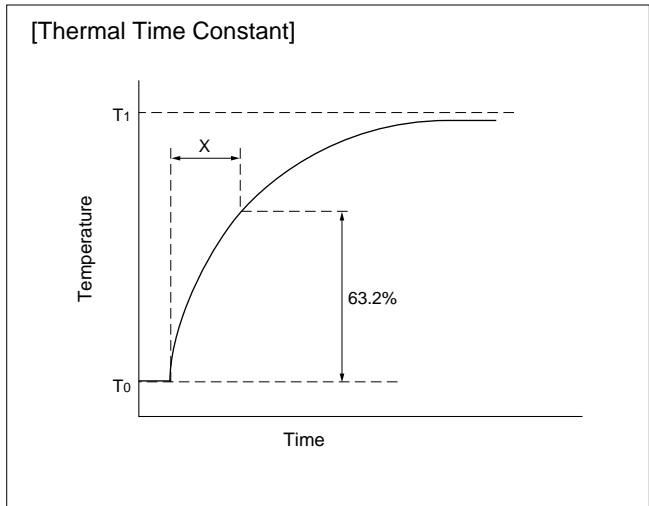

Performance

Item	Condition
Resistance	Measured by zero-power in specified ambient temperature.
B-Constant	Calculated between two specified ambient temperatures by next formula. T and T ₀ is absolute temperature (K). $B = \frac{\ell n (R/R_0)}{1/T-1/T_0}$
Thermal Dissipation Constant	Shows necessary electric power that Thermistor's temperature rises 1°C by self heating. It is calculated by next formula. (mW/°C) $C = \frac{P}{T-T_0}$
Rated Electric Power	Shows necessary electric power that Thermistor's temperature rises 100°C by self heating in ambient temperature 25°C.
Permissive Operating Current	It is possible to keep Thermistor's temperature rising max. 1°C

Please inquire about test conditions and ratings.

NTC Thermistors



for Temperature Compensation 0201 (0603) Size

0201/0402/0603/0805 sized Chip NTC Thermistors have Ni barrier termination and provide excellent solderability and offer high stability in environment by unique inner construction.

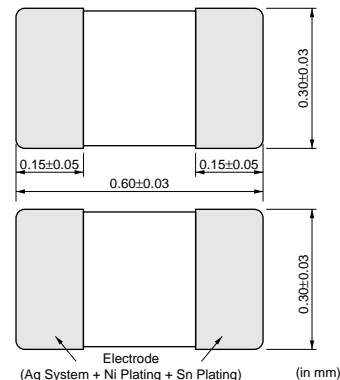

■ Features

1. Excellent solderability and high stability in environment
2. Excellent long time aging stability
3. High accuracy in resistance and B-constant
4. Reflow soldering possible
5. Lead is not contained in the product.

■ Applications

1. Temperature compensation of transistor, IC, crystal oscillator of mobile communications equipment
2. Temperature sensor for rechargeable batteries
3. Temperature compensation of LCD
4. Temperature compensation and sensing of car audio equipment (CD, MD, Tuner)
5. Temperature compensation of several kinds of circuits

Part Number	Resistance (25°C) (k ohm)	B-Constant (25-50°C) (K)	Permissible Operating Current (25°C) (mA)	Rated Electric Power (25°C) (mW)	Typical Dissipation Constant (25°C) (mW/°C)	Operating Temperature Range (°C)
NCP03XH103□05RL	10	3380 ±3%	0.31	100	1.0	-40 to 125
NCP03WB473□05RL	47	4050 ±3%	0.14	100	1.0	-40 to 125

A blank column is filled with resistance tolerance codes. (J: ±5%, K: ±10%)

■ Standard Land Dimensions

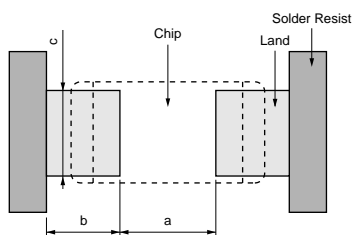

Soldering Methods	a	b	c
Reflow Soldering	0.25	0.25	0.3

(in mm)

NTC Thermistors



for Temperature Compensation 0402 (1005) Size

2

0201/0402/0603/0805 sized Chip NTC Thermistors have Ni barrier termination and provide excellent solderability and offer high stability in environment by unique inner construction.

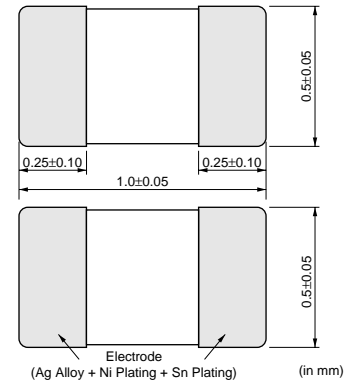
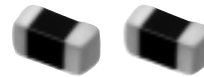

■ Features

1. Excellent solderability and high stability in environment
2. Excellent long time aging stability
3. High accuracy in resistance and B-constant
4. Reflow soldering possible
5. Same B-constant in the same resistance in the three sizes (0805 size/0603 size/0402 size)
Easy to use smaller size in the circuits
6. Lead is not contained in the product.
7. NCP15, 18, 21 series are recognized by UL (UL1434, File No.E137188 Vol.2, Sec.2).

■ Applications

1. Temperature compensation of transistor, IC, crystal oscillator of mobile communications equipments
2. Temperature sensor for rechargeable batteries
3. Temperature compensation of LCD
4. Temperature compensation and sensing of car audio equipments (CD, MD, Tuner)
5. Temperature compensation of several kinds of circuits

Part Number	Resistance (25°C)	B-Constant (25-50°C) (K)	Permissible Operating Current (25°C) (mA)	Rated Electric Power (25°C) (mW)	Typical Dissipation Constant (25°C) (mW/°C)	Operating Temperature Range (°C)
NCP15XC220□03RC	22ohm	3100 ±3%	6.70	100	1.0	-40 to 125
NCP15XC330□03RC	33ohm	3100 ±3%	5.50	100	1.0	-40 to 125
NCP15XC470□03RC	47ohm	3100 ±3%	4.60	100	1.0	-40 to 125
NCP15XC680□03RC	68ohm	3100 ±3%	3.80	100	1.0	-40 to 125
NCP15XF101□03RC	100ohm	3250 ±3%	3.10	100	1.0	-40 to 125
NCP15XF151□03RC	150ohm	3250 ±3%	2.50	100	1.0	-40 to 125
NCP15XM221□03RC	220ohm	3500 ±3%	2.10	100	1.0	-40 to 125
NCP15XM331□03RC	330ohm	3500 ±3%	1.70	100	1.0	-40 to 125
NCP15XQ471□03RC	470ohm	3650 ±3%	1.40	100	1.0	-40 to 125
NCP15XQ681□03RC	680ohm	3650 ±3%	1.20	100	1.0	-40 to 125
NCP15XQ102□03RC	1.0k ohm	3650 ±3%	1.00	100	1.0	-40 to 125
NCP15XW152□03RC	1.5k ohm	3950 ±3%	0.81	100	1.0	-40 to 125
NCP15XW222□03RC	2.2k ohm	3950 ±3%	0.67	100	1.0	-40 to 125
NCP15XW332□03RC	3.3k ohm	3950 ±3%	0.55	100	1.0	-40 to 125
NCP15XM472□03RC	4.7k ohm	3500 ±3%	0.46	100	1.0	-40 to 125
NCP15XW682□03RC	6.8k ohm	3950 ±3%	0.38	100	1.0	-40 to 125
NCP15XH103□03RC	10k ohm	3380 ±3%	0.31	100	1.0	-40 to 125
NCP15XV103□03RC	10k ohm	3900 ±3%	0.31	100	1.0	-40 to 125
NCP15XW153□03RC	15k ohm	3950 ±3%	0.25	100	1.0	-40 to 125
NCP15XW223□03RC	22k ohm	3950 ±3%	0.21	100	1.0	-40 to 125
NCP15WL223□03RC	22k ohm	4485 ±1%	0.21	100	1.0	-40 to 125
NCP15WB333□03RC	33k ohm	4050 ±3%	0.17	100	1.0	-40 to 125

Continued on the following page.



Continued from the preceding page.

Part Number	Resistance (25°C)	B-Constant (25-50°C) (K)	Permissive Operating Current (25°C) (mA)	Rated Electric Power (25°C) (mW)	Typical Dissipation Constant (25°C) (mW/°C)	Operating Temperature Range (°C)
NCP15WL333□03RC	33k ohm	4485 ±1%	0.17	100	1.0	-40 to 125
NCP15WB473□03RC	47k ohm	4050 ±3%	0.14	100	1.0	-40 to 125
NCP15WL473□03RC	47k ohm	4485 ±1%	0.14	100	1.0	-40 to 125
NCP15WD683□03RC	68k ohm	4150 ±3%	0.12	100	1.0	-40 to 125
NCP15WL683□03RC	68k ohm	4485 ±1%	0.12	100	1.0	-40 to 125
NCP15WF104□03RC	100k ohm	4250 ±3%	0.10	100	1.0	-40 to 125
NCP15WL104□03RC	100k ohm	4485 ±1%	0.10	100	1.0	-40 to 125
NCP15WL154□03RC	150k ohm	4485 ±1%	0.08	100	1.0	-40 to 125
NCP15WM154□03RC	150k ohm	4500 ±3%	0.08	100	1.0	-40 to 125
NCP15WM224□03RC	220k ohm	4500 ±3%	0.06	100	1.0	-40 to 125
NCP15WM474□03RC	470k ohm	4500 ±3%	0.04	100	1.0	-40 to 125

A blank column is filled with resistance tolerance codes. (J: ±5%, K: ±10%)

Tolerance ±1% is also available for the following type.

10k ohm: NCP15XH103F03RC

47k ohm: NCP15WB473F03RC

100k ohm: NCP15WF104F03RC

Standard Land Dimensions

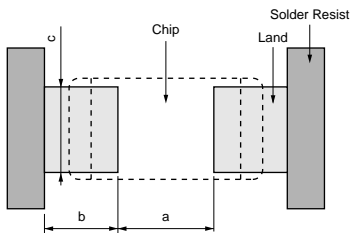

Soldering Methods	a	b	c
Reflow Soldering	0.4	0.4-0.5	0.5

(in mm)

NTC Thermistors



for Temperature Compensation 0603 (1608) Size

0201/0402/0603/0805 sized Chip NTC Thermistors have Ni barrier termination and provide excellent solderability and offer high stability in environment by unique inner construction.

■ Features

1. Excellent solderability and high stability in environment
2. Excellent long time aging stability
3. High accuracy in resistance and B-constant
4. Flow/Reflow soldering possible
5. Same B-constant in the same resistance in the three sizes (0805 size/0603 size/0402 size)
Easy to use smaller size in the circuits
6. Lead is not contained in the product.
7. NCP15, 18, 21 series are recognized by UL (UL1434, File No.E137188 Vol.2, Sec.2).

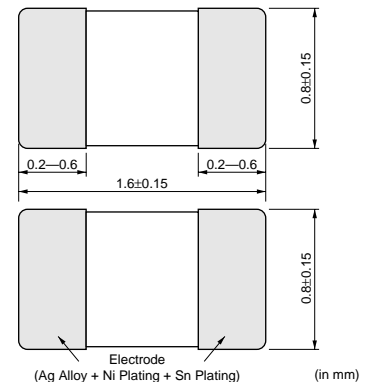

3

■ Applications

1. Temperature compensation of transistor, IC, crystal oscillator of mobile communications equipments
2. Temperature sensor for rechargeable batteries
3. Temperature compensation of LCD
4. Temperature compensation and sensing of car audio equipments (CD, MD, Tuner)
5. Temperature compensation of several kinds of circuits

Part Number	Resistance (25°C)	B-Constant (25-50°C) (K)	Permissible Operating Current (25°C) (mA)	Rated Electric Power (25°C) (mW)	Typical Dissipation Constant (25°C) (mW/°C)	Operating Temperature Range (°C)
NCP18XF101□03RB	100ohm	3250 ±3%	3.10	100	1.0	-40 to 125
NCP18XF151□03RB	150ohm	3250 ±3%	2.50	100	1.0	-40 to 125
NCP18XM221□03RB	220ohm	3500 ±3%	2.10	100	1.0	-40 to 125
NCP18XM331□03RB	330ohm	3500 ±3%	1.70	100	1.0	-40 to 125
NCP18XQ471□03RB	470ohm	3650 ±3%	1.40	100	1.0	-40 to 125
NCP18XQ681□03RB	680ohm	3650 ±3%	1.20	100	1.0	-40 to 125
NCP18XQ102□03RB	1.0k ohm	3650 ±3%	1.00	100	1.0	-40 to 125
NCP18XW152□03RB	1.5k ohm	3950 ±3%	0.81	100	1.0	-40 to 125
NCP18XW222□03RB	2.2k ohm	3950 ±3%	0.67	100	1.0	-40 to 125
NCP18XW332□03RB	3.3k ohm	3950 ±3%	0.55	100	1.0	-40 to 125
NCP18XM472□03RB	4.7k ohm	3500 ±3%	0.46	100	1.0	-40 to 125
NCP18XW682□03RB	6.8k ohm	3950 ±3%	0.38	100	1.0	-40 to 125
NCP18XH103□03RB	10k ohm	3380 ±3%	0.31	100	1.0	-40 to 125
NCP18XW153□03RB	15k ohm	3950 ±3%	0.25	100	1.0	-40 to 125
NCP18XW223□03RB	22k ohm	3950 ±3%	0.21	100	1.0	-40 to 125
NCP18WB333□03RB	33k ohm	4050 ±3%	0.17	100	1.0	-40 to 125
NCP18WB473□03RB	47k ohm	4050 ±3%	0.14	100	1.0	-40 to 125
NCP18WD683□03RB	68k ohm	4150 ±3%	0.12	100	1.0	-40 to 125
NCP18WF104□03RB	100k ohm	4250 ±3%	0.10	100	1.0	-40 to 125
NCP18WM154□03RB	150k ohm	4500 ±3%	0.08	100	1.0	-40 to 125
NCP18WM224□03RB	220k ohm	4500 ±3%	0.06	100	1.0	-40 to 125
NCP18WM474□03RB	470k ohm	4500 ±3%	0.04	100	1.0	-40 to 125

Both flow and reflow soldering methods can be employed. A blank column is filled with resistance tolerance codes. (J: ±5%, K: ±10%)
Tolerance ±1% NCP18XH103F03RB is also available for 10k ohm type.



■ Standard Land Dimensions

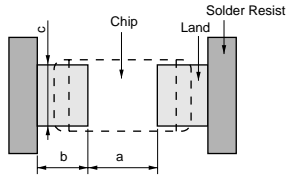

Soldering Methods	a	b	c
Flow Soldering	0.6-1.0	0.8-0.9	0.6-0.8
Reflow Soldering	0.6-0.8	0.6-0.7	0.6-0.8

(in mm)

NTC Thermistors



for Temperature Compensation 0805 (2012) Size

0201/0402/0603/0805 sized Chip NTC Thermistors have Ni barrier termination and provide excellent solderability and offer high stability in environment by unique inner construction.

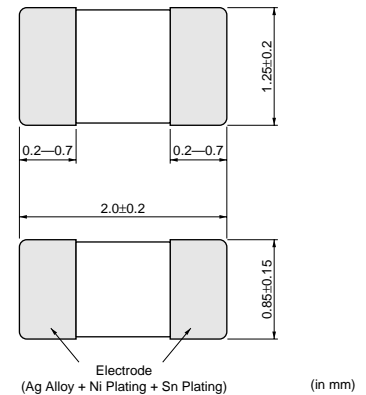

■ Features

1. Excellent solderability and high stability in environment
2. Excellent long time aging stability
3. High accuracy in resistance and B-constant
4. Flow/Reflow soldering possible
5. Same B-constant in the same resistance in the three sizes (0805 size/0603 size/0402 size)
Easy to use smaller size in the circuits
6. Lead is not contained in the product.
7. NCP15, 18, 21 series are recognized by UL (UL1434, File No.E137188 Vol.2, Sec.2).

■ Applications

1. Temperature compensation of transistor, IC, crystal oscillator of mobile communications equipments
2. Temperature sensor for rechargeable batteries
3. Temperature compensation of LCD
4. Temperature compensation and sensing of car audio equipments (CD, MD, Tuner)
5. Temperature compensation of several kinds of circuits

Part Number	Resistance (25°C)	B-Constant (25-50°C) (K)	Permissible Operating Current (25°C) (mA)	Rated Electric Power (25°C) (mW)	Typical Dissipation Constant (25°C) (mW/°C)	Operating Temperature Range (°C)
NCP21XM221□03RA	220ohm	3500 ±3%	3.00	200	2.0	-40 to 125
NCP21XQ471□03RA	470ohm	3650 ±3%	2.00	200	2.0	-40 to 125
NCP21XQ102□03RA	1.0k ohm	3650 ±3%	1.40	200	2.0	-40 to 125
NCP21XW222□03RA	2.2k ohm	3950 ±3%	0.90	200	2.0	-40 to 125
NCP21XM472□03RA	4.7k ohm	3500 ±3%	0.65	200	2.0	-40 to 125
NCP21XV103□03RA	10k ohm	3900 ±3%	0.44	200	2.0	-40 to 125
NCP21XW153□03RA	15k ohm	3950 ±3%	0.36	200	2.0	-40 to 125
NCP21XW223□03RA	22k ohm	3950 ±3%	0.30	200	2.0	-40 to 125
NCP21WB333□03RA	33k ohm	4050 ±3%	0.24	200	2.0	-40 to 125
NCP21WB473□03RA	47k ohm	4050 ±3%	0.20	200	2.0	-40 to 125
NCP21WF104□03RA	100k ohm	4250 ±3%	0.14	200	2.0	-40 to 125

Both flow and reflow soldering methods can be employed.
A blank column is filled with resistance tolerance codes. (J: ±5%, K: ±10%)

4

■ Standard Land Dimensions

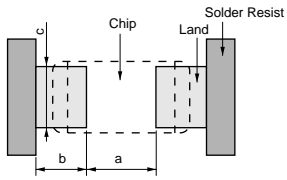

Soldering Methods	a	b	c
Flow Soldering	1.0~1.1	0.9~1.0	1.0~1.2
Reflow Soldering	1.0~1.1	0.6~0.7	1.0~1.2

(in mm)

for Temperature Compensation Temperature Characteristics (Reference Value)

Temp. (°C)	NCP15XC220J type			NCP15XC330J type			NCP15XC470J type			NCP15XC680J type		
	Resistance (Ω)			Resistance (Ω)			Resistance (Ω)			Resistance (Ω)		
	Low	Center	High	Low	Center	High	Low	Center	High	Low	Center	High
-40	310.9516	355.8225	406.1506	466.4273	533.7338	609.2259	664.3056	760.1664	867.6854	961.1230	1099.8152	1255.3746
-35	241.3103	273.9749	310.2836	361.9654	410.9624	465.4253	515.5265	585.3101	662.8785	745.8681	846.8316	959.0583
-30	189.0297	213.0028	239.4162	283.5445	319.5042	359.1243	403.8362	455.0514	511.4800	584.2736	658.3723	740.0136
-25	149.2410	166.9433	186.2785	223.8615	250.4150	279.4177	318.8331	356.6516	397.9586	461.2905	516.0066	575.7699
-20	118.8349	131.9972	146.2508	178.2524	197.9958	219.3762	253.8746	281.9940	312.4449	367.3080	407.9914	452.0480
-15	95.4608	105.3183	115.9033	143.1912	157.9775	173.8549	203.9390	224.9983	247.6116	295.0607	325.5294	358.2465
-10	77.2491	84.6699	92.5716	115.8737	127.0049	138.8573	165.0322	180.8857	197.7665	238.7700	261.7070	286.1303
-5	63.0090	68.6279	74.5612	94.5134	102.9419	111.8417	134.6100	146.6143	159.2898	194.7549	212.1227	230.4618
0	51.7128	55.9813	60.4506	77.5692	83.9719	90.6759	110.4773	119.5964	129.1445	159.8395	173.0330	186.8474
5	42.6169	45.8594	49.2252	63.9253	68.7891	73.8379	91.0452	97.9724	105.1630	131.7250	141.7472	152.1508
10	35.3484	37.8185	40.3601	53.0226	56.7278	60.5402	75.5170	80.7941	86.2239	109.2587	116.8936	124.7494
15	29.5096	31.3959	33.3193	44.2644	47.0938	49.9789	63.0432	67.0730	71.1821	91.2114	97.0418	102.9869
20	24.7701	26.2112	27.6667	37.1552	39.3168	41.5001	52.9180	55.9966	59.1062	76.5622	81.0164	85.5153
25	20.9000	22.0000	23.1000	31.3500	33.0000	34.6500	44.6500	47.0000	49.3500	64.6000	68.0000	71.4000
30	17.5424	18.5602	19.5878	26.3137	27.8402	29.3817	37.4770	39.6513	41.8467	54.2221	57.3678	60.5442
35	14.7988	15.7351	16.6889	22.1983	23.6027	25.0333	31.6157	33.6160	35.6535	45.7419	48.6359	51.5837
40	12.5445	13.4025	14.2835	18.8168	20.1038	21.4252	26.7996	28.6327	30.5147	38.7739	41.4260	44.1489
45	10.6779	11.4619	12.2727	16.0168	17.1928	18.4090	22.8118	24.4867	26.2189	33.0043	35.4276	37.9338
50	9.1270	9.8420	10.5865	13.6905	14.7630	15.8798	19.4986	21.0261	22.6167	28.2107	30.4208	32.7220
55	7.8362	8.4877	9.1704	11.7543	12.7316	13.7556	16.7410	18.1328	19.5913	24.2210	26.2348	28.3449
60	6.7546	7.3479	7.9733	10.1318	11.0218	11.9600	14.4302	15.6977	17.0339	20.8777	22.7116	24.6448
65	5.8578	6.3988	6.9723	8.7867	9.5982	10.4585	12.5144	13.6702	14.8955	18.1059	19.7782	21.5509
70	5.1010	5.5946	6.1207	7.6515	8.3919	9.1810	10.8976	11.9522	13.0760	15.7667	17.2925	18.9185
75	4.4466	4.8964	5.3783	6.6698	7.3446	8.0674	9.4994	10.4605	11.4899	13.7439	15.1343	16.6237
80	3.8888	4.2989	4.7405	5.8332	6.4484	7.1107	8.3078	9.1841	10.1274	12.0199	13.2876	14.6524
85	3.4197	3.7946	4.2000	5.1296	5.6919	6.3001	7.3058	8.1067	8.9728	10.5701	11.7288	12.9820
90	3.0173	3.3603	3.7329	4.5260	5.0404	5.5994	6.4461	7.1788	7.9749	9.3262	10.3863	11.5381
95	2.6689	2.9829	3.3256	4.0033	4.4744	4.9883	5.7017	6.3726	7.1046	8.2493	9.2199	10.2790
100	2.3678	2.6556	2.9710	3.5517	3.9834	4.4565	5.0584	5.6734	6.3471	7.3186	8.2083	9.1831
105	2.1034	2.3672	2.6575	3.1551	3.5509	3.9863	4.4936	5.0573	5.6775	6.5014	7.3170	8.2142
110	1.8734	2.1155	2.3830	2.8101	3.1733	3.5745	4.0023	4.5196	5.0909	5.7906	6.5389	7.3656
115	1.6776	1.9005	2.1476	2.5164	2.8507	3.2215	3.5839	4.0602	4.5882	5.1853	5.8743	6.6382
120	1.5062	1.7117	1.9404	2.2593	2.5676	2.9106	3.2178	3.6569	4.1454	4.6556	5.2908	5.9976
125	1.3533	1.5427	1.7543	2.0299	2.3140	2.6314	2.8910	3.2958	3.7477	4.1828	4.7683	5.4222

Temp. (°C)	NCP□□XF101J type			NCP□□XF151J type			NCP□□XM221J type			NCP□□XM331J type		
	Resistance (Ω)			Resistance (Ω)			Resistance (Ω)			Resistance (Ω)		
	Low	Center	High	Low	Center	High	Low	Center	High	Low	Center	High
-40	1588.3934	1824.1748	2089.7183	2382.5901	2736.2622	3134.5775	4281.3910	4947.9037	5703.8815	6422.0865	7421.8556	8555.8223
-35	1220.8309	1390.6851	1580.2105	1831.2464	2086.0276	2370.3158	3232.8028	3703.7546	4232.7058	4849.2043	5555.6318	6349.0587
-30	947.2895	1070.6526	1207.0558	1420.9343	1605.9790	1810.5837	2463.5987	2798.8729	3171.8255	3695.3981	4198.3094	4757.7383
-25	740.9805	831.1384	929.9356	1111.4707	1246.7076	1394.9034	1895.3406	2135.8872	2400.9454	2843.0109	3203.8309	3601.4182
-20	584.6168	650.9600	723.0199	876.9252	976.4400	1084.5298	1471.2503	1645.0366	1834.7523	2206.8755	2467.5549	2752.1285
-15	465.2849	514.4408	567.3679	697.9274	771.6612	851.0519	1151.7079	1278.0338	1414.6703	1727.5619	1917.0507	2122.0054
-10	373.0915	409.6997	448.7753	559.6372	614.5496	673.1630	908.3588	1000.6201	1099.4967	1362.5382	1500.9302	1649.2450
-5	301.4711	328.8767	357.8766	452.2066	493.3150	536.8150	721.9176	789.6120	861.4951	1082.8764	1184.4181	1292.2426
0	245.1757	265.7593	287.3508	367.7635	398.6389	431.0262	577.8973	627.7522	680.2030	866.8464	941.6283	1020.3045
5	200.3198	215.7848	231.8627	300.4797	323.6772	347.7940	465.6678	502.4737	540.8332	698.5017	753.7106	811.2498
10	164.7460	176.3948	188.3951	247.1190	264.5922	282.5927	377.7788	405.0095	433.1175	566.6681	607.5142	649.6763
15	136.3699	145.1611	154.1328	204.5548	217.7417	231.1992	308.3256	328.4797	349.0764	462.4884	492.7196	523.6146
20	113.5174	120.1519	126.8562	170.2760	180.2278	190.2843	253.1370	268.0437	283.1186	379.7056	402.0655	424.6779
25	95.0000	100.0000	105.0000	142.5000	150.0000	157.5000	209.0000	220.0000	231.0000	313.5000	330.0000	346.5000
30	79.0612	83.6687	88.3233	118.5918	125.5030	132.4850	171.5071	181.5764	191.7562	257.2606	272.3645	287.6344
35	66.1414	70.3607	74.6620	99.2122	105.5411	111.9930	141.5184	150.6681	160.0084	212.2777	226.0022	240.0126
40	55.6090	59.4560	63.4102	83.4136	89.1841	95.1154	117.4077	125.6805	134.1997	176.1116	188.5207	201.2996
45	46.9726	50.4697	54.0915	70.4590	75.7045	81.1372	97.8822	105.3357	113.0734	146.8233	158.0036	169.6100
50	39.8560	43.0286	46.3377	59.7840	64.5429	69.5065	82.0161	88.7172	95.7259	123.0241	133.0758	143.5889
55	33.9559	36.8303	39.8482	50.9338	55.2455	59.7723	69.0420	75.0585	81.3954	103.5629	112.5878	122.0932
60	29.0460	31.6485	34.3979	43.5691	47.4727	51.5968	58.3788	63.7771	69.5003	87.5683	95.6656	104.2504
65	25.0041	27.3636	29.8708	37.5062	41.0453	44.8062	49.5725	54.4149	59.5811	74.3587	81.6224	89.3717
70	21.6157	23.7560	26.0429	32.4236	35.6340	39.0644	42.2849	46.6309	51.2951	63.4274	69.9464	76.9427
75	18.7113	20.6506	22.7339	28.0669	30.9759	34.1008	36.2121	40.1147	44.3268	54.3182	60.1721	66.4903
80	16.2524	18.0106	19.9092	24.3787	27.0160	29.8637	31.1296	34.6367	38.4425	46.6944	51.9550	57.6638
85	14.2018	15.8001	17.5343	21.3026	23.7001	26.3014	26.8580	30.0126	33.4539	40.2870	45.0189	50.1808
90	12.4534	13.9081	15.4938	18.6801	20.8621	23.2407	23.2681	26.1099	29.2256	34.9021	39.1649	43.8384
95	10.9385	12.2625	13.7123	16.4078	18.3937	20.5684	20.2272	22.7904	25.6142	30.3407	34.1856	38.4213
100	9.6371	10.8435	12.1703	14.4557	16.2652	18.2555	17.6416	19.9565	22.5187	26.4624	29.9347	33.7781
105	8.5212	9.6223	10.8386	12.7819	14.4335	16.2578	15.4465	17.5411	19.8700	23.1698	26.3117	29.8050
110	7.5562	8.5625	9.6786	11.3343	12.8438	14.5179	13.5562	15.4531	17.5715	20.3343	23.1797	26.3572
115	6.7265	7.6482	8.6744	10.0897	11.4723	13.0116	11.9416	13.6629	15.5934	17.9123	20.4944	23.3900
120	6.0044	6.8497	7.7946	9.0065	10.2746	11.6918	10.5495	12.1139	13.8754	15.8243	18.1708	20.8131
125	5.3842	6.1618	7.0340	8.0763	9.2426	10.5510	9.3537	10.7784	12.3891	14.0305	16.1676	18.5837

Continued on the following page. ↗

for Temperature Compensation Temperature Characteristics (Reference Value)

↳ Continued from the preceding page.

Temp. (°C)	NCP□□XQ471J type			NCP□□XQ681J type			NCP□□XQ102J type			NCP□□XW152J type		
	Resistance (Ω)			Resistance (Ω)			Resistance (kΩ)			Resistance (kΩ)		
	Low	Center	High	Low	Center	High	Low	Center	High	Low	Center	High
-40	10195.6193	11822.4726	13674.6409	14751.1087	17104.8540	19784.5868	21.6928	25.1542	29.0950	44.2420	51.7912	60.4770
-35	7629.3548	8767.7450	10050.8064	11038.2154	12685.2480	14541.5923	16.2327	18.6548	21.3847	32.0716	37.1724	42.9768
-30	5766.8583	6570.2235	7466.7895	8343.5396	9505.8552	10803.0146	12.2699	13.9792	15.8868	23.5236	27.0048	30.9236
-25	4400.5140	4971.7838	5603.1722	6366.7012	7193.2191	8106.7172	9.3628	10.5783	11.9216	17.4452	19.8426	22.5130
-20	3387.9463	3796.9333	4244.6543	4901.7096	5493.4355	6141.2019	7.2084	8.0786	9.0312	13.0647	14.7278	16.5611
-15	2629.0453	2923.3995	3242.5836	3803.7251	4229.5993	4691.3975	5.5937	6.2200	6.8991	9.8817	11.0439	12.3118
-10	2056.6347	2269.5988	2498.3537	2975.5566	3283.6749	3614.6394	4.3758	4.8289	5.3156	7.5445	8.3617	9.2442
-5	1620.5498	1775.2252	1939.8021	2344.6253	2568.4109	2806.5222	3.4480	3.7771	4.1272	5.8112	6.3888	7.0063
0	1286.3077	1399.0503	1517.8704	1861.0410	2024.1579	2196.0679	2.7368	2.9767	3.2295	4.5122	4.9221	5.3557
5	1027.8581	1110.2196	1196.1827	1487.1139	1606.2752	1730.6473	2.1869	2.3622	2.5451	3.5327	3.8245	4.1301
10	826.9792	887.2572	949.5490	1196.4806	1283.6913	1373.8156	1.7595	1.8878	2.0203	2.7856	2.9936	3.2092
15	669.3557	713.4632	758.5760	968.4295	1032.2446	1097.5142	1.4242	1.5180	1.6140	2.2129	2.3613	2.5134
20	545.1310	577.3750	609.9977	788.7002	835.3513	882.5499	1.1599	1.2285	1.2979	1.7699	1.8756	1.9826
25	446.5000	470.0000	493.5000	646.0000	680.0000	714.0000	0.9500	1.0000	1.0500	1.4250	1.5000	1.5750
30	363.3735	384.8004	406.4720	525.7319	556.7325	588.0872	0.7731	0.8187	0.8648	1.1396	1.2074	1.2760
35	297.3779	316.7570	336.5555	430.2488	458.2867	486.9313	0.6327	0.6740	0.7161	0.9172	0.9780	1.0401
40	244.7447	262.1771	280.1490	354.0986	379.3200	405.3220	0.5207	0.5578	0.5961	0.7428	0.7969	0.8528
45	202.4473	218.0688	234.3085	292.9025	315.5038	338.9995	0.4307	0.4640	0.4985	0.6051	0.6531	0.7030
50	168.3307	182.2969	196.9284	243.5424	263.7488	284.9176	0.3582	0.3879	0.4190	0.4958	0.5382	0.5828
55	140.6799	153.1503	166.3093	203.5369	221.5791	240.6177	0.2993	0.3259	0.3538	0.4085	0.4459	0.4856
60	118.1215	129.2486	141.0702	170.8993	186.9979	204.1015	0.2513	0.2750	0.3001	0.3383	0.3713	0.4066
65	99.6242	109.5508	120.1654	144.1371	158.4991	173.8563	0.2120	0.2331	0.2557	0.2817	0.3108	0.3421
70	84.4206	93.2811	102.8140	122.1404	134.9600	148.7522	0.1796	0.1985	0.2188	0.2355	0.2613	0.2891
75	71.8361	79.7499	88.3142	103.9331	115.3828	127.7737	0.1528	0.1697	0.1879	0.1981	0.2208	0.2456
80	61.3721	68.4463	76.1450	88.7937	99.0287	110.1673	0.1306	0.1456	0.1620	0.1672	0.1873	0.2094
85	52.6633	58.9961	65.9251	76.1938	85.3560	95.3809	0.1120	0.1255	0.1403	0.1418	0.1597	0.1793
90	45.3599	51.0359	57.2785	65.6271	73.8391	82.8710	0.0965	0.1086	0.1219	0.1208	0.1367	0.1542
95	39.2354	44.3318	49.9651	56.7661	64.1397	72.2899	0.0835	0.0943	0.1063	0.1033	0.1174	0.1331
100	34.0575	38.6403	43.7302	49.2747	55.9052	63.2693	0.0725	0.0822	0.0930	0.0888	0.1013	0.1153
105	29.6631	33.7903	38.3956	42.9169	48.8881	55.5510	0.0631	0.0719	0.0817	0.0766	0.0877	0.1003
110	25.9394	29.6642	33.8390	37.5294	42.9184	48.9586	0.0552	0.0631	0.0720	0.0663	0.0763	0.0876
115	22.7557	26.1228	29.9131	32.9232	37.7947	43.2785	0.0484	0.0556	0.0636	0.0575	0.0665	0.0767
120	20.0407	23.0913	26.5397	28.9950	33.4086	38.3979	0.0426	0.0491	0.0565	0.0502	0.0582	0.0674
125	17.7029	20.4715	23.6139	25.6127	29.6183	34.1648	0.0377	0.0436	0.0502	0.0439	0.0511	0.0594

Temp. (°C)	NCP□□XW222J type			NCP□□XW332J type			NCP□□XM472J type			NCP□□XW682J type		
	Resistance (kΩ)			Resistance (kΩ)			Resistance (kΩ)			Resistance (kΩ)		
	Low	Center	High	Low	Center	High	Low	Center	High	Low	Center	High
-40	64.8883	75.9605	88.6996	97.3324	113.9407	133.0495	91.4661	105.7052	121.8557	200.5638	234.7869	274.1625
-35	47.0383	54.5195	63.0326	70.5575	81.7793	94.5489	69.0644	79.1257	90.4260	145.3912	168.5150	194.8281
-30	34.5013	39.6070	45.3547	51.7519	59.4105	68.0320	52.6314	59.7941	67.7617	106.6403	122.4217	140.1871
-25	25.5863	29.1025	33.0190	38.3795	43.6537	49.5285	40.4914	45.6303	51.2929	79.0850	89.9531	102.0588
-20	19.1616	21.6008	24.2896	28.7424	32.4012	36.4344	31.4313	35.1440	39.1970	59.2268	66.7661	75.0769
-15	14.4932	16.1977	18.0573	21.7398	24.2965	27.0859	24.6047	27.3034	30.2225	44.7972	50.0655	55.8134
-10	11.0653	12.2638	13.5581	16.5979	18.3956	20.3372	19.4058	21.3769	23.4892	34.2017	37.9062	41.9069
-5	8.5230	9.3702	10.2759	12.7846	14.0554	15.4138	15.4228	16.8690	18.4047	26.3439	28.9626	31.7619
0	6.6179	7.2190	7.8551	9.9269	10.8286	11.7826	12.3460	13.4111	14.5316	20.4554	22.3134	24.2794
5	5.1813	5.6093	6.0575	7.7719	8.4140	9.0863	9.9484	10.7347	11.5542	16.0149	17.3379	18.7232
10	4.0856	4.3907	4.7068	6.1283	6.5860	7.0602	8.0707	8.6525	9.2530	12.6281	13.5712	14.5482
15	3.2456	3.4633	3.6863	4.8684	5.1949	5.5294	6.5870	7.0175	7.4575	10.0319	10.7046	11.3939
20	2.5959	2.7509	2.9079	3.8938	4.1263	4.3618	5.4079	5.7264	6.0484	8.0237	8.5028	8.9880
25	2.0900	2.2000	2.3100	3.1350	3.3000	3.4650	4.4650	4.7000	4.9350	6.4600	6.8000	7.1400
30	1.6714	1.7709	1.8715	2.5071	2.6563	2.8073	3.6640	3.8791	4.0966	5.1661	5.4735	5.7848
35	1.3453	1.4344	1.5256	2.0179	2.1516	2.2883	3.0233	3.2188	3.4184	4.1582	4.4335	4.7153
40	1.0895	1.1688	1.2507	1.6342	1.7532	1.8761	2.5083	2.6850	2.8670	3.3675	3.6126	3.8659
45	0.8875	0.9578	1.0311	1.3313	1.4367	1.5467	2.0911	2.2504	2.4157	2.7432	2.9605	3.1871
50	0.7272	0.7894	0.8548	1.0908	1.1841	1.2821	1.7522	1.8953	2.0451	2.2478	2.4400	2.6420
55	0.5991	0.6540	0.7122	0.8987	0.9811	1.0683	1.4750	1.6035	1.7389	1.8518	2.0216	2.2013
60	0.4962	0.5446	0.5963	0.7442	0.8169	0.8945	1.2472	1.3625	1.4848	1.5336	1.6834	1.8431
65	0.4131	0.4559	0.5018	0.6197	0.6838	0.7527	1.0590	1.1625	1.2729	1.2769	1.4091	1.5511
70	0.3455	0.3832	0.4240	0.5182	0.5748	0.6360	0.9034	0.9962	1.0959	1.0678	1.1845	1.3106
75	0.2905	0.3229	0.3602	0.4357	0.4858	0.5403	0.7736	0.8570	0.9470	0.8979	1.0010	1.1133
80	0.2452	0.2748	0.3071	0.3679	0.4122	0.4606	0.6650	0.7400	0.8213	0.7580	0.8493	0.9492
85	0.2080	0.2342	0.2630	0.3121	0.3513	0.3945	0.5738	0.6412	0.7147	0.6430	0.7239	0.8130
90	0.1772	0.2004	0.2261	0.2658	0.3007	0.3392	0.4971	0.5578	0.6244	0.5478	0.6196	0.6990
95	0.1516	0.1722	0.1952	0.2273	0.2583	0.2928	0.4321	0.4869	0.5472	0.4685	0.5323	0.6033
100	0.1302	0.1486	0.1692	0.1953	0.2229	0.2538	0.3769	0.4263	0.4811	0.4025	0.4593	0.5229
105	0.1123	0.1287	0.1471	0.1684	0.1930	0.2207	0.3300	0.3747	0.4245	0.3470	0.3978	0.4548
110	0.0972	0.1118	0.1284	0.1458	0.1678	0.1926	0.2896	0.3301	0.3754	0.3003	0.3457	0.3969
115	0.0844	0.0975	0.1124	0.1266	0.1463	0.1687	0.2551	0.2919	0.3331	0.2608	0.3015	0.3475
120	0.0736	0.0854	0.0988	0.1104	0.1281	0.1483	0.2254	0.2588	0.2964	0.2274	0.2639	0.3055
125	0.0644	0.0750	0.0871	0.0966	0.1125	0.1307	0.1998	0.2303	0.2647	0.1990	0.2318	0.2694

Continued on the following page. ↗

for Temperature Compensation Temperature Characteristics (Reference Value)

Continued from the preceding page.

Temp. (°C)	NCP□□XH103J type			NCP□□XV103J type			NCP□□XW153J type			NCP□□XW223J type		
	Resistance (kΩ)			Resistance (kΩ)			Resistance (kΩ)			Resistance (kΩ)		
	Low	Center	High	Low	Center	High	Low	Center	High	Low	Center	High
-40	170.0056	195.6520	224.6043	281.4484	328.9962	383.6153	442.4201	517.9122	604.7702	648.8828	759.6046	886.9963
-35	129.8266	148.1710	168.6845	205.0766	237.3866	274.1001	320.7159	371.7242	429.7679	470.3834	545.1955	630.3263
-30	100.1156	113.3471	128.0065	151.0349	173.1845	198.0859	235.2360	270.0479	309.2363	345.0129	396.0702	453.5466
-25	77.9389	87.5588	98.1201	112.4526	127.7730	144.8177	174.4523	198.4259	225.1297	255.8634	291.0246	330.1902
-20	61.1957	68.2367	75.8975	84.6373	95.3267	107.0977	130.6473	147.2781	165.6109	191.6160	216.0079	242.8960
-15	48.4622	53.6496	59.2437	64.2461	71.7459	79.9208	98.8174	110.4385	123.1178	144.9322	161.9765	180.5728
-10	38.6653	42.5062	46.6117	49.2630	54.5638	60.2838	75.4449	83.6166	92.4417	110.6525	122.6377	135.5811
-5	31.0399	33.8922	36.9140	38.0536	41.8131	45.8290	58.1116	63.8880	70.0629	85.2304	93.7024	102.7590
0	25.0925	27.2186	29.4511	29.6512	32.3301	35.1629	45.1222	49.2208	53.5574	66.1792	72.1905	78.5508
5	20.4304	22.0211	23.6762	23.2798	25.1938	27.1971	35.3270	38.2453	41.3011	51.8130	56.0931	60.5750
10	16.7337	17.9255	19.1542	18.4153	19.7854	21.2044	27.8561	29.9364	32.0916	40.8555	43.9067	47.0677
15	13.7804	14.6735	15.5855	14.6698	15.6508	16.6557	22.1292	23.6131	25.1336	32.4561	34.6325	36.8626
20	11.4116	12.0805	12.7567	11.7668	12.4683	13.1786	17.6993	18.7561	19.8264	25.9589	27.5090	29.0787
25	9.5000	10.0000	10.5000	9.5000	10.0000	10.5000	14.2500	15.0000	15.7500	20.9000	22.0000	23.1000
30	7.8552	8.3145	8.7787	7.6195	8.0723	8.5305	11.3959	12.0740	12.7605	16.7139	17.7085	18.7154
35	6.5288	6.9479	7.3754	6.1497	6.5559	6.9714	9.1724	9.7799	10.4015	13.4529	14.3438	15.2555
40	5.4531	5.8336	6.2252	4.9940	5.3562	5.7303	7.4283	7.9691	8.5278	10.8949	11.6880	12.5074
45	4.5726	4.9169	5.2739	4.0789	4.4007	4.7359	6.0512	6.5306	7.0303	8.8751	9.5782	10.3111
50	3.8502	4.1609	4.4854	3.3500	3.6350	3.9344	4.9583	5.3823	5.8279	7.2722	7.8940	8.5475
55	3.2551	3.5350	3.8293	2.7668	3.0189	3.2858	4.0850	4.4593	4.8558	5.9913	6.5403	7.1219
60	2.7624	3.0143	3.2809	2.2976	2.5206	2.7584	3.3829	3.7133	4.0657	4.9616	5.4462	5.9631
65	2.3591	2.5861	2.8279	1.9176	2.1148	2.3265	2.8166	3.1082	3.4214	4.1310	4.5587	5.0181
70	2.0230	2.2275	2.4467	1.6066	1.7810	1.9694	2.3554	2.6128	2.8911	3.4546	3.8321	4.2403
75	1.7401	1.9245	2.1232	1.3546	1.5091	1.6771	1.9806	2.2082	2.4558	2.9049	3.2387	3.6018
80	1.5022	1.6685	1.8486	1.1468	1.2838	1.4336	1.6721	1.8734	2.0938	2.4524	2.7477	3.0709
85	1.3019	1.4521	1.6156	0.9749	1.0966	1.2304	1.4185	1.5969	1.7933	2.0804	2.3421	2.6302
90	1.1322	1.2680	1.4165	0.8323	0.9405	1.0601	1.2083	1.3667	1.5419	1.7722	2.0044	2.2615
95	0.9868	1.1096	1.2445	0.7137	0.8101	0.9173	1.0334	1.1741	1.3308	1.5156	1.7221	1.9518
100	0.8627	0.9738	1.0965	0.6144	0.7005	0.7966	0.8878	1.0132	1.1534	1.3021	1.4860	1.6917
105	0.7572	0.8580	0.9697	0.5309	0.6078	0.6942	0.7655	0.8775	1.0032	1.1228	1.2870	1.4714
110	0.6665	0.7580	0.8600	0.4607	0.5297	0.6074	0.6625	0.7626	0.8756	0.9717	1.1185	1.2842
115	0.5883	0.6715	0.7646	0.4012	0.4631	0.5332	0.5753	0.6650	0.7666	0.8438	0.9753	1.1244
120	0.5206	0.5964	0.6815	0.3505	0.4062	0.4695	0.5017	0.5822	0.6739	0.7359	0.8539	0.9884
125	0.4621	0.5311	0.6090	0.3075	0.3577	0.4151	0.4390	0.5113	0.5942	0.6438	0.7500	0.8715

Temp. (°C)	NCP□□WB333J type			NCP15WL333J type			NCP□□WB473J type			NCP□□WD683J type		
	Resistance (kΩ)			Resistance (kΩ)			Resistance (kΩ)			Resistance (kΩ)		
	Low	Center	High	Low	Center	High	Low	Center	High	Low	Center	High
-40	1046.0404	1227.2628	1436.2815	1361.2577	1610.1538	1899.7972	1489.8151	1747.9197	2045.6131	2325.9631	2735.3593	3208.7719
-35	752.9420	874.4491	1013.0257	966.2331	1130.8501	1320.2041	1072.3720	1245.4275	1442.7942	1664.5604	1937.3907	2249.3020
-30	548.5400	630.8514	723.7003	692.8641	802.6093	927.4130	781.2539	898.4853	1030.7247	1205.6590	1389.3445	1597.0123
-25	404.1776	460.4568	523.2611	501.6937	575.3848	658.2502	575.6469	655.8022	745.2507	883.2052	1008.0144	1147.5848
-20	300.9970	339.7972	382.6399	366.6647	416.4640	471.8442	428.6928	483.9536	544.9720	653.5386	738.9776	833.4974
-15	226.4171	253.3626	282.8061	270.3769	304.2188	341.4409	322.4729	360.8498	402.7844	488.5367	547.4555	611.9463
-10	171.9353	190.7661	211.1301	201.0863	224.1931	249.3301	244.8776	271.6971	300.7004	368.7125	409.5999	453.8837
-5	131.7346	144.9635	159.1220	150.7866	166.6233	183.6630	187.6220	206.4631	226.6283	280.7073	309.2166	339.7697
0	101.7587	111.0867	120.9667	113.9660	124.8498	136.4311	144.9290	158.2144	172.2859	215.6355	235.6064	256.7833
5	79.2440	85.8417	92.7563	86.7951	94.2865	102.1685	112.8627	122.2594	132.1074	166.9555	180.9801	195.6923
10	62.1868	66.8613	71.7074	66.5895	71.7465	77.1096	88.5691	95.2267	102.1287	130.2753	140.1394	150.3734
15	49.1580	52.4701	55.8655	51.4516	54.9959	58.6373	70.0128	74.7302	79.5660	102.4068	109.3437	116.4586
20	39.1283	41.4709	43.8440	40.0290	42.4554	44.9164	55.7281	59.0647	62.4445	81.0612	85.9287	90.8607
25	31.3500	33.0000	34.6500	31.3500	33.0000	34.6500	44.6500	47.0000	49.3500	64.6000	68.0000	71.4000
30	24.9421	26.4303	27.9372	24.3505	25.8215	27.3128	35.5236	37.6431	39.7894	51.1085	54.1668	57.2645
35	19.9693	21.2983	22.6589	19.0399	20.3353	21.6644	28.4412	30.3339	32.2718	40.6980	43.4205	46.2092
40	16.0869	17.2658	18.4849	14.9840	16.1154	17.2890	22.9116	24.5907	26.3270	32.6091	35.0157	37.5059
45	13.0349	14.0761	15.1626	11.8663	12.8493	13.8790	18.5648	20.0478	21.5952	26.2879	28.4056	30.6173
50	10.6207	11.5377	12.5026	9.4550	10.3062	11.2060	15.1264	16.4325	17.8067	21.3078	23.1657	25.1226
55	8.6995	9.5058	10.3608	7.5787	8.3144	9.0987	12.3902	13.5385	14.7563	17.3695	18.9967	20.7244
60	7.1620	7.8702	8.6269	6.1102	6.7455	7.4283	10.2005	11.2091	12.2868	14.2330	15.6569	17.1803
65	5.9272	6.5494	7.2187	4.9542	5.5029	6.0970	8.4418	9.3279	10.2811	11.7211	12.9669	14.3092
70	4.9285	5.4751	6.0672	4.0393	4.5134	5.0305	7.0194	7.7979	8.6411	9.7029	10.7935	11.9765
75	4.1145	4.5950	5.1187	3.3113	3.7214	4.1719	5.8601	6.5443	7.2902	8.0657	9.0206	10.0634
80	3.4514	3.8742	4.3379	2.7289	3.0843	3.4771	4.9156	5.5178	6.1782	6.7376	7.5749	8.4949
85	2.9088	3.2815	3.6926	2.2607	2.5691	2.9123	4.1429	4.6736	5.2591	5.6522	6.3872	7.1997
90	2.4600	2.7887	3.1534	1.8824	2.1507	2.4510	3.5036	3.9717	4.4912	4.7611	5.4071	6.1255
95	2.0883	2.3787	2.7026	1.5753	1.8091	2.0725	2.9742	3.3878	3.8492	4.0288	4.5978	5.2341
100	1.7805	2.0375	2.3258	1.3248	1.5291	1.7605	2.5358	2.9019	3.3125	3.4199	3.9216	4.4856
105	1.5235	1.7513	2.0082	1.1195	1.2985	1.5024	2.1698	2.4943	2.8602	2.9156	3.3589	3.8599
110	1.3071	1.5093	1.7384	0.9505	1.1077	1.2878	1.8616	2.1496	2.4759	2.4945	2.8869	3.3326
115	1.1259	1.3058	1.5106	0.8108	0.9493	1.1087	1.6036	1.8598	2.1514	2.1415	2.4894	2.8865
120	0.9738	1.1341	1.3176	0.6948	0.8172	0.9587	1.3869	1.6153	1.8765	1.8460	2.1552	2.5098
125	0.8441	0.9872	1.1517	0.5981	0.7065	0.8325	1.2023	1.4060	1.6403	1.5950	1.8701	2.1871

Continued on the following page.

for Temperature Compensation Temperature Characteristics (Reference Value)

↳ Continued from the preceding page.

Temp. (°C)	NCP□□WF104J type			NCP□□WM154J type			NCP□□WM224J type			NCP□□WM474J type		
	Resistance (kΩ)			Resistance (kΩ)			Resistance (kΩ)			Resistance (kΩ)		
	Low	Center	High	Low	Center	High	Low	Center	High	Low	Center	High
-40	3729.0380	4397.1193	5171.9295	6663.0974	7899.4664	9341.8362	9772.5429	11585.8840	13701.3597	20877.7053	24751.6612	29271.0867
-35	2647.2336	3088.5989	3594.5428	4661.8142	5466.1177	6393.1650	6837.3274	8016.9727	9376.6420	14607.0177	17127.1689	20031.9170
-30	1902.5755	2197.2250	2531.1628	3305.2450	3834.4985	4437.3776	4847.6927	5623.9311	6508.1538	10356.4343	12014.7619	13903.7832
-25	1383.3182	1581.8805	1804.4223	2369.2950	2720.5227	3116.0075	3474.9659	3990.1000	4570.1443	7423.7909	8524.3045	9763.4901
-20	1016.2022	1151.0367	1300.5024	1716.3371	1951.2163	2212.6929	2517.2944	2861.7839	3245.2829	5377.8563	6113.8111	6933.1044
-15	754.3293	846.5788	947.7345	1257.2112	1415.5649	1589.8796	1843.9098	2076.1619	2331.8235	3939.2618	4435.4368	4981.6229
-10	565.4664	628.9882	697.8966	929.6193	1036.9837	1153.8561	1363.4416	1520.9094	1692.3223	2912.8070	3249.2156	3615.4158
-5	427.6799	471.6321	518.8009	693.9071	767.0791	845.8472	1017.7304	1125.0494	1240.5760	2174.2421	2403.5146	2650.3214
0	326.4567	357.0117	389.4505	522.6028	572.6674	625.9593	766.4841	839.9121	918.0736	1637.4887	1794.3578	1961.3390
5	251.2051	272.4995	294.8601	396.9240	431.2641	467.4038	582.1552	632.5207	685.5255	1243.6953	1351.2943	1464.5318
10	194.8470	209.7098	225.1420	303.8361	327.4052	351.9206	445.6263	480.1943	516.1503	952.0198	1025.8697	1102.6846
15	152.2795	162.6506	173.2936	234.3761	250.5378	267.1443	343.7517	367.4554	391.8117	734.3785	785.0184	837.0523
20	119.8614	127.0802	134.3970	182.1203	193.1657	204.3687	267.1098	283.3096	299.7408	570.6436	605.2524	640.3553
25	95.0000	100.0000	105.0000	142.5000	150.0000	157.5000	209.0000	220.0000	231.0000	446.5000	470.0000	493.5000
30	74.7365	79.2216	83.7660	110.5975	117.2810	124.0574	162.2097	172.0121	181.9509	346.5388	367.4804	388.7133
35	59.1874	63.1671	67.2459	86.4105	92.2934	98.3303	126.7354	135.3636	144.2178	270.7529	289.1859	308.1016
40	47.1711	50.6766	54.3066	67.9535	73.0895	78.4173	99.6651	107.1980	115.0120	212.9209	229.0139	245.7074
45	37.8301	40.9035	44.1161	53.7797	58.2400	62.9125	78.8770	85.4186	92.2716	168.5099	182.4853	197.1257
50	30.5087	33.1946	36.0267	42.8052	46.6645	50.7445	62.7810	68.4412	74.4252	134.1230	146.2153	158.9993
55	24.7475	27.0909	29.5820	34.2719	37.6046	41.1581	50.2655	55.1533	60.3652	107.3854	117.8276	128.9620
60	20.1817	22.2243	24.4126	27.5792	30.4531	33.5424	40.4494	44.6645	49.1955	86.4147	95.4197	105.0996
65	16.5424	18.3225	20.2434	22.3250	24.8037	27.4886	32.7434	36.3787	40.3166	69.9518	77.7182	86.1309
70	13.6319	15.1841	16.8709	18.1552	20.2927	22.6252	26.6276	29.7626	33.1836	56.8863	63.5838	70.8922
75	11.2813	12.6354	14.1166	14.8345	16.6789	18.7057	21.7572	24.4623	27.4350	46.4814	52.2604	58.6111
80	9.3830	10.5657	11.8678	12.1829	13.7764	15.5394	17.8683	20.2054	22.7911	38.1732	43.1662	48.6902
85	7.8382	8.8726	10.0184	10.0498	11.4282	12.9632	14.7397	16.7614	19.0126	31.4894	35.8084	40.6179
90	6.5752	7.4811	8.4905	8.3256	9.5195	10.8574	12.2108	13.9619	15.9242	26.0867	29.8277	34.0200
95	5.5415	6.3365	7.2274	6.9299	7.9661	9.1344	10.1638	11.6836	13.3972	21.7136	24.9605	28.6212
100	4.6855	5.3839	6.1709	5.7872	6.6876	7.7088	8.4879	9.8085	11.3062	18.1333	20.9545	24.1541
105	3.9793	4.5942	5.2910	4.8547	5.6388	6.5332	7.1203	8.2703	9.5820	15.2115	17.6683	20.4706
110	3.3918	3.9342	4.5520	4.0875	4.7715	5.5561	5.9950	6.9983	8.1490	12.8075	14.9508	17.4092
115	2.9011	3.3804	3.9291	3.4538	4.0516	4.7410	5.0655	5.9423	6.9534	10.8218	12.6949	14.8550
120	2.4918	2.9164	3.4048	2.9307	3.4544	4.0616	4.2983	5.0665	5.9570	9.1828	10.8239	12.7263
125	2.1455	2.5220	2.9573	2.4951	2.9549	3.4906	3.6595	4.3338	5.1195	7.8181	9.2586	10.9371

Temp. (°C)	NCP□□XH103F type			NCP15WB473F type			NCP15WF104F type		
	Resistance (kΩ)			Resistance (kΩ)			Resistance (kΩ)		
	Low	Center	High	Low	Center	High	Low	Center	High
-40	188.0202	195.6520	203.5731	1639.0806	1747.9197	1863.7996	4191.5221	4397.1193	4612.3399
-35	142.7877	148.1710	153.7418	1173.8304	1245.4275	1321.2596	2954.6027	3088.5989	3228.3492
-30	109.5221	113.3471	117.2940	850.9910	898.4853	948.5354	2109.0700	2197.2250	2288.8359
-25	84.8227	87.5588	90.3741	624.0766	655.8022	689.0716	1523.4112	1581.8805	1642.4297
-20	66.2694	68.2367	70.2554	462.6455	483.9536	506.1925	1112.0223	1151.0367	1191.3009
-15	52.2283	53.6496	55.1040	346.4840	360.8498	375.7736	820.4005	846.5788	873.5051
-10	41.4765	42.5062	43.5570	261.9935	271.6971	281.7320	611.3519	628.9882	647.0685
-5	33.1462	33.8922	34.6515	199.9109	206.4631	213.2088	459.7296	471.6321	483.7943
0	26.6780	27.2186	27.7675	153.8063	158.2144	162.7327	348.9722	357.0117	365.1999
5	21.6294	22.0211	22.4175	119.3135	122.2594	125.2655	267.0836	272.4995	277.9974
10	17.6430	17.9255	18.2107	93.2812	95.2267	97.2031	206.0809	209.7098	213.3813
15	14.4712	14.6735	14.8772	73.4700	74.7302	76.0043	160.2427	162.6506	165.0781
20	11.9371	12.0805	12.2244	58.2739	59.0647	59.8601	125.5083	127.0802	128.6590
25	9.9000	10.0000	10.1000	46.5300	47.0000	47.4700	99.0000	100.0000	101.0000
30	8.2162	8.3145	8.4132	37.1428	37.6431	38.1463	78.2470	79.2216	80.2004
35	6.8534	6.9479	7.0430	29.8340	30.3339	30.8392	62.2488	63.1671	64.0926
40	5.7443	5.8336	5.9238	24.1094	24.5907	25.0792	49.8300	50.6766	51.5325
45	4.8333	4.9169	5.0015	19.5953	20.0478	20.5088	40.1341	40.9035	41.6835
50	4.0833	4.1609	4.2395	16.0137	16.4325	16.8605	32.5022	33.1946	33.8983
55	3.4634	3.5350	3.6076	13.1552	13.5385	13.9316	26.4720	27.0909	27.7215
60	2.9486	3.0143	3.0812	10.8610	11.2091	11.5673	21.6737	22.2243	22.7867
65	2.5259	2.5861	2.6476	9.0133	9.3279	9.6525	17.8340	18.3225	18.8224
70	2.1724	2.2275	2.2839	7.5147	7.7979	8.0910	14.7516	15.1841	15.6278
75	1.8741	1.9245	1.9761	6.2901	6.5443	6.8082	12.2529	12.6354	13.0285
80	1.6225	1.6685	1.7157	5.2899	5.5178	5.7549	10.2276	10.5657	10.9139
85	1.4101	1.4521	1.4952	4.4694	4.6736	4.8866	8.5736	8.8726	9.1810
90	1.2296	1.2680	1.3074	3.7890	3.9717	4.1629	7.2167	7.4811	7.7543
95	1.0746	1.1096	1.1456	3.2242	3.3878	3.5593	6.1024	6.3365	6.5789
100	0.9419	0.9738	1.0067	2.7553	2.9019	3.0559	5.1766	5.3839	5.5989
105	0.8288	0.8580	0.8881	2.3630	2.4943	2.6327	4.4103	4.5942	4.7853
110	0.7313	0.7580	0.7856	2.0319	2.1496	2.2739	3.7709	3.9342	4.1042
115	0.6471	0.6715	0.6968	1.7541	1.8598	1.9716	3.2351	3.3804	3.5318
120	0.5740	0.5964	0.6196	1.5203	1.6153	1.7161	2.7870	2.9164	3.0516
125	0.5106	0.5311	0.5524	1.3206	1.4060	1.4969	2.4066	2.5220	2.6427

Chip Type ⚠Caution/Notice

■ ⚠Caution (Storage and Operating Conditions)

This product is designed for application in an ordinary environment (normal room temperature, humidity and atmospheric pressure).

Do not use under the following conditions because all these factors can deteriorate the product characteristics or cause failures and burn-out.

1. Corrosive gas or deoxidizing gas
(Chlorine gas, Hydrogen sulfide gas, Ammonia gas, Sulfuric acid gas, Nitric oxide gas, etc.)

2. Volatile or flammable gas
3. Dusty conditions
4. Under high or low pressure
5. Wet or humid locations
6. Places with salt water, oils, chemical liquids or organic solvents
7. Strong vibrations
8. Other places where similar hazardous conditions exist

■ ⚠Caution (Others)

Be sure to provide an appropriate fail-safe function on your product to prevent secondary damages that may be caused by the abnormal function or the failure of our product.

■ Notice (Storage and Operating Conditions)

To keep solderability of product from declining, the following storage condition is recommended.

1. Storage condition:
Temperature -10 to +40 degree C
Humidity less than 75%RH (not dewing condition)
2. Storage term:
Use this product within 6 months after delivery by first-in and first-out stocking system.

3. Handling after unpacking:
After unpacking, reseal product promptly or store it in a sealed container with a drying agent.
4. Storage place:
Do not store this product in corrosive gas (sulfuric acid gas, chlorine gas, etc.) or in direct sunlight.

■ Notice (Rating)

Use this product within the specified temperature range.

Higher temperature may cause deterioration of the characteristics or the material quality of this product.

■ Notice (Handling)

The ceramic of this product is fragile, and care must be taken not to load a excessive press-force or not to give a shock at handling.

Such forces may cause cracking or chipping.

Chip Type ⚠️Caution/Notice

■ Mounting Position

Choose a mounting position that minimizes the stress imposed on the chip during flexing or bending of the board.

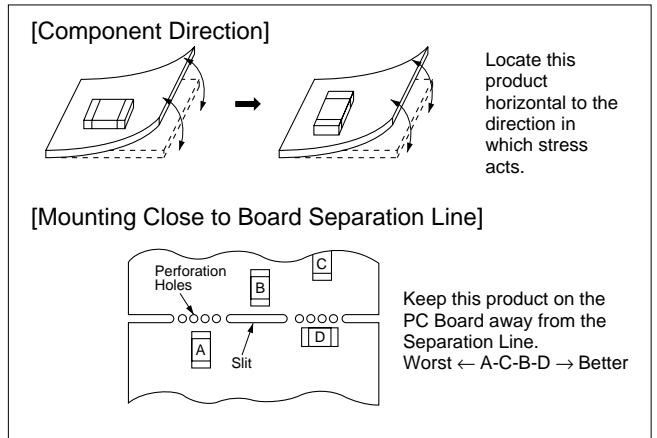

■ Reflow Soldering Conditions (NCP03/NCP15 Series)

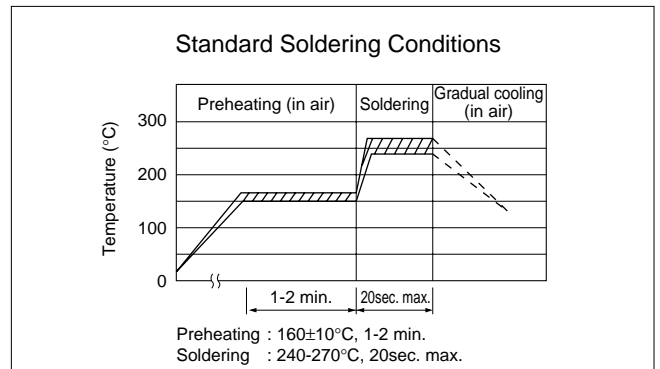
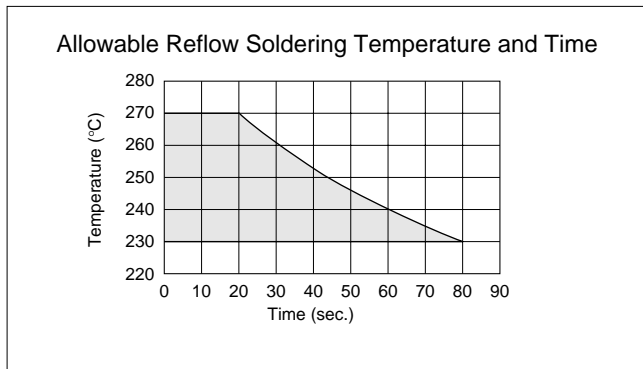

(NCP18/21 Series)

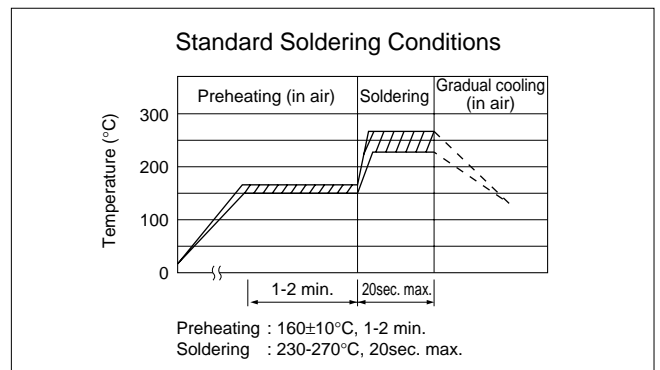
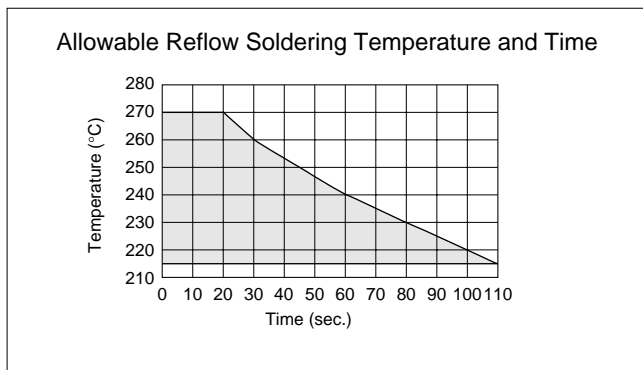

■ Flow Soldering Conditions (NCP18/21 Series)

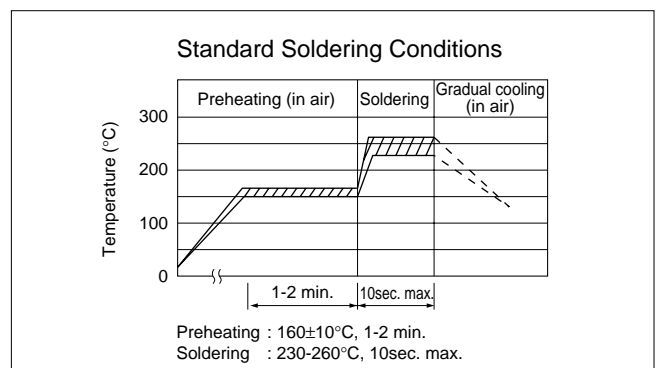
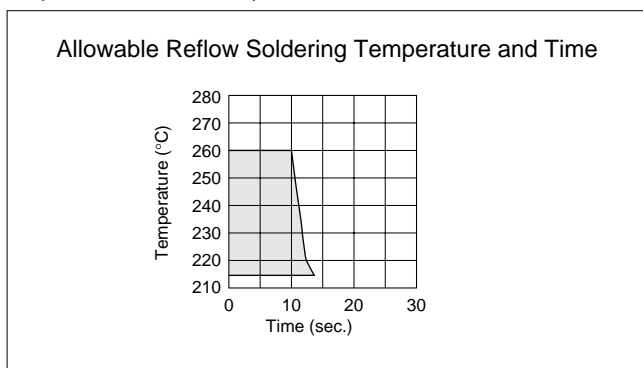

Continued on the following page. ↗

Chip Type ⚠Caution/Notice

☐ Continued from the preceding page.

■ Solder and Flux

1. Solder and Paste

(1) Reflow Soldering : NCP03/15/18/21 Series

Use RA/RMA type or equivalent type of solder paste. For your reference, we are using the solder paste below for any internal tests of this product.

- RMA9086 90-4-M20 (Sn:Pb=63wt%:37wt%)
(Manufactured by Alpha Metals Japan Ltd.,)
- M705-221BM5-42-11 (Sn:Ag:Cu=96.5wt%:3.0wt%:0.5wt%)
(Manufactured by Senju Metal Industry Co., LTD)

(2) Flow Soldering : NCP18/21 Series

We are using the solder paste below. For any internal tests of this product.

- Sn : Pb=63wt%:37wt%
- Sn : Ag : Cu=96.5wt% : 3.0wt% : 0.5wt%

2. Flux

Use Rosin-based flux.

Do not use strong acidic flux (with halide content exceeding 0.2wt%)

■ Cleaning Conditions

For removing the flux after soldering, observe the following points in order to avoid deterioration of the characteristics or any change of the external electrodes' quality.

	NCP03/15	NCP18/21
Solvent	Isopropyl Alcohol	Isopropyl Alcohol
Dipping Cleaning	Less than 5min. at room temp. or less than 2min. at 40°C max.	Less than 5min. at room temp. or less than 2min. at 40°C max.
Ultrasonic Cleaning	Less than 5min. 20W/ℓ Frequency of 28 to 40kHz.	Less than 1min. 20W/ℓ Frequency of several 10kHz to 100kHz.

■ Drying

After cleaning, promptly dry this product.

■ Printing Conditions of Solder Paste

- The amount of solder is critical. Standard height of fillet is shown in the table below.
- Too much soldering may cause mechanical stress, resulting in cracking, mechanical and/or electronic damage.

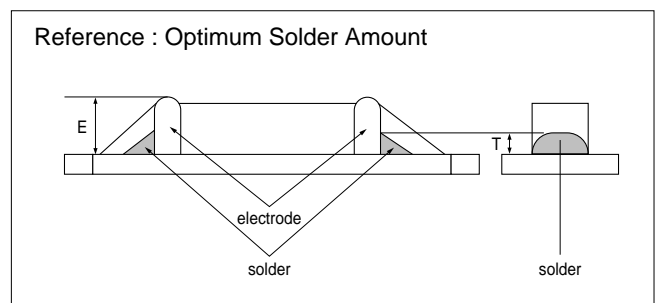

Part Number	The solder paste thickness	T
NCP03	100μm	$1/3E \leq T \leq E$
NCP15	100μm	$1/3E \leq T \leq E$
NCP18/NCP21	150μm	$0.2mm \leq T \leq E$

■ Adhesive Application and Curing

- Thin or insufficient adhesive may result in loose component contact with land during flow soldering.
- Low viscosity adhesive causes chips to slip after mounting.

Chip Type Package

■ Minimum Quantity Guide

Part Number	Quantity (pcs.)	
	Paper Tape	Plastic Tape
NCP03	15000	-
NCP15	10000	
NCP18	4000	
NCP21	-	4000

■ Tape Carrier Packaging

1. Dimensions of Reel

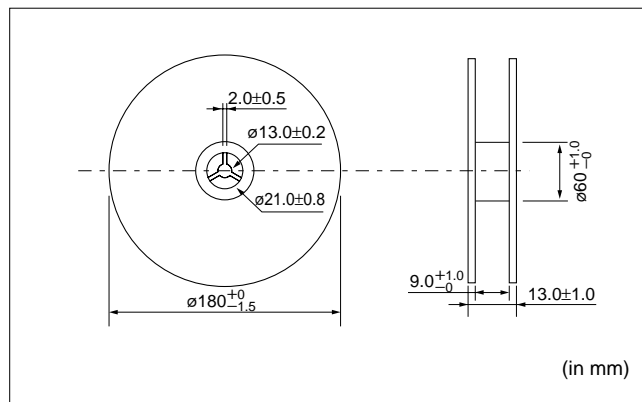

2. Taping Method

- (1) A tape in a reel contains Leader unit and Trailer unit where products are not packed. (Please refer to the figure right.)
- (2) The top and base tapes or, plastic and cover tape are not stucked at the first five pitches minimum.
- (3) A label should be attached on the reel. (MURATA's part number, inspection number and quantity should be marked on the label.)
- (4) Taping reels are packed in a package.

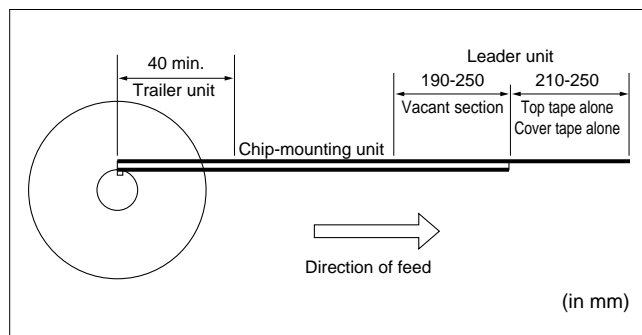

Continued on the following page.

Chip Type Package

☐ Continued from the preceding page.

3. Paper Tape (NCP03/15/18 Series)

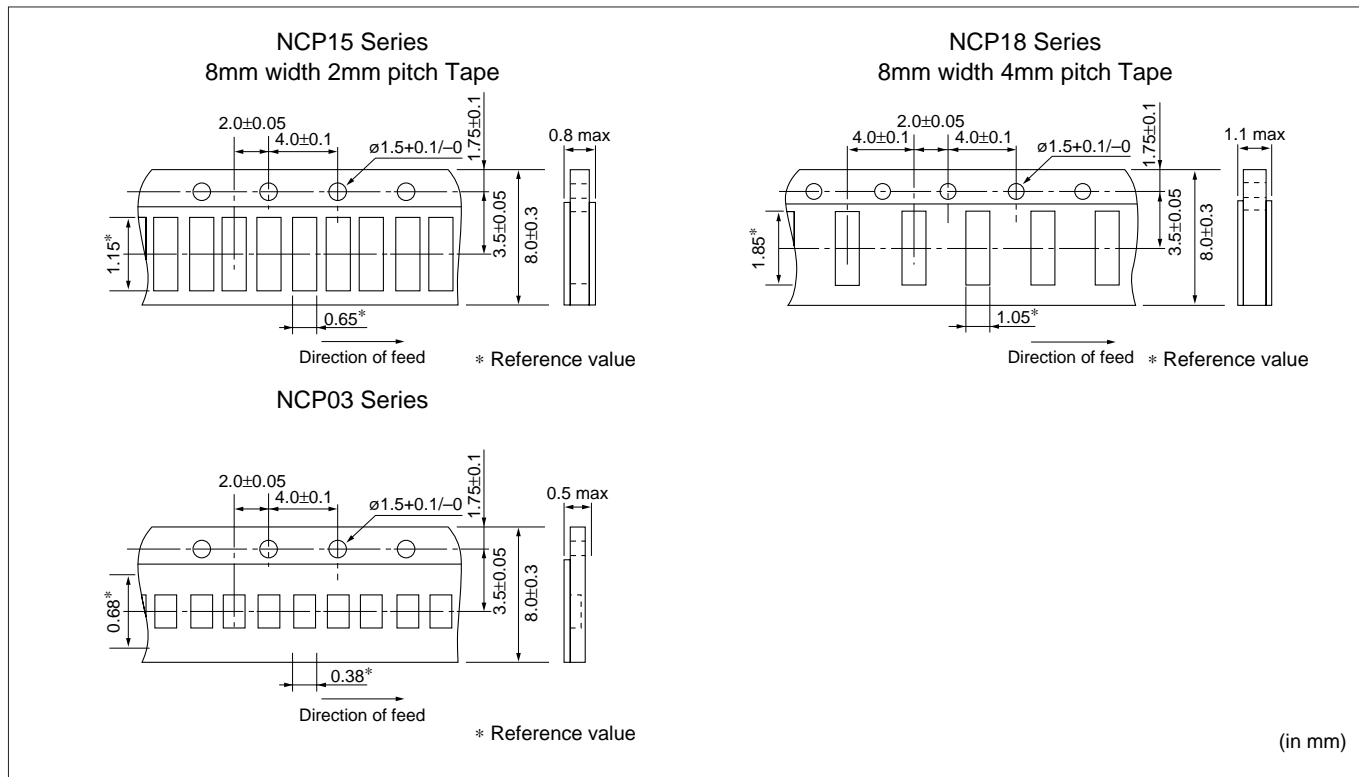

(1) Other Conditions

① Packaging

Products are packaged in the cavity of the base tape and sealed by top tape and bottom tape.

② Tape

Top tape and bottom tape have no joints and products are packaged and sealed in the cavity of the base tape, continuously.

(2) Peeling force of top tape

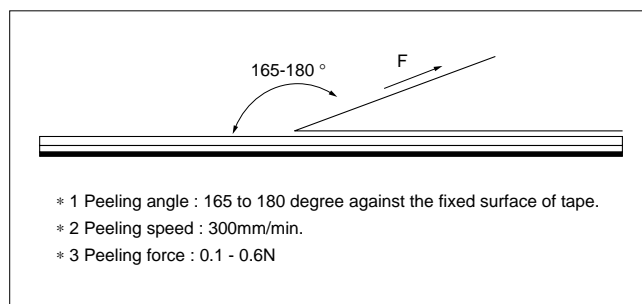

(3) Pull Strength

Pull strength of top tape is specified at 10N minimum.

Pull strength of bottom tape are specified 5N minimum.

Continued on the following page. ☐

Chip Type Package

☐ Continued from the preceding page.

4. Plastic tape (NCP21 Series)

(1) Other Conditions

① Packaging

Products are packaged in the each embossed cavity of plastic tape and sealed by cover tape.

② Tape

Cover tape has no joints.

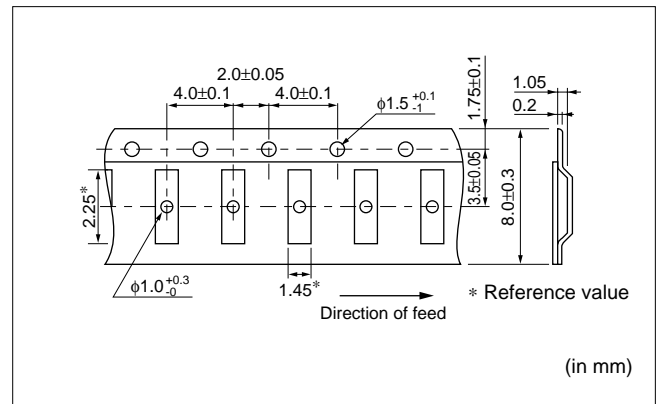

(2) Peeling force of cover tape

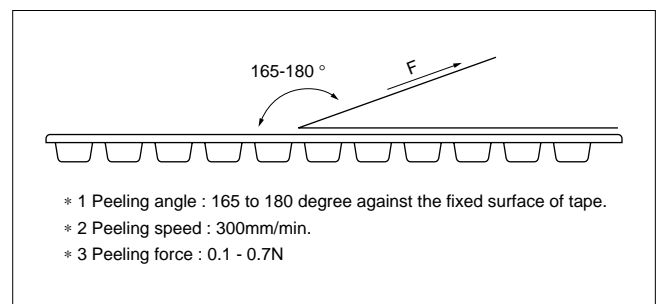

(3) Tape Strength

Pull strength of plastic tape and cover tape shall be specified 10N minimum.

NTC Thermistors



for Temperature Sensor Resin Coated Radial Lead Type

This product is a sensor type NTC Thermistor to be useful in the normal temperature range developed by the unique ceramic technology and the automatic assembly.

■ Features

1. High-accuracy of +-1%
+-1% of resistance and B-Constant tolerance is realized due to uniform thickness by the precise sheet forming method.
2. Quick response
This product provides faster response time due to its smaller size.
3. Taping type is available (Standard type)
4. Strong lead strength
Original lead-wiring technique assures reliable connection. It can be formed and bent flexibly according to the mounting conditions.
5. Lead Coating type
The lead wires of Lead Coating type are coated with strong and flexible resin.

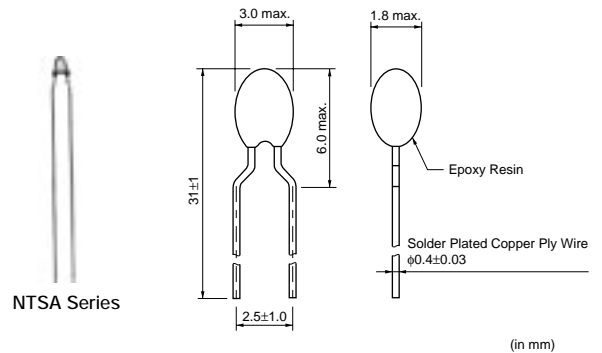
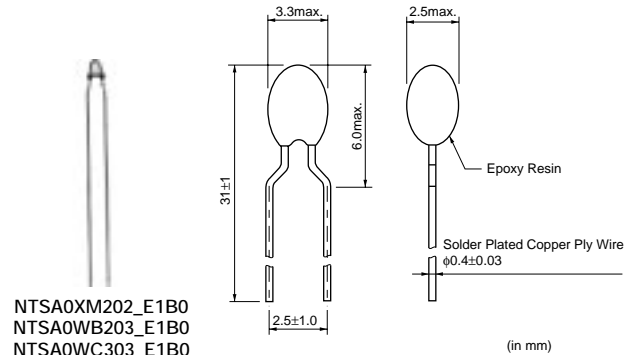

■ Applications

1. Rechargeable batteries
2. Battery charging circuits
3. Head of printers
4. DC fan motors
5. Home appliance equipments

Part Number	Resistance (25°C) (k ohm)	B-Constant (25-50°C) (K)	Permissible Operating Current (25°C) (mA)	Rated Electric Power (25°C) (mW)	Typical Dissipation Constant (25°C) (mW/°C)	Thermal Time Constant (25°C)(s)	Operating Temperature Range (°C)
NTSA0XM202□E1B0	2.0	3500 ±1%	1.05	21	2.1	7	-40 to 125
NTSA0XR502□E1B0	5.0	3700 ±1%	0.68	21	2.1	7	-40 to 125
NTSA0XH103□E1B0	10	3380 ±1%	0.38	15	1.5	7	-40 to 125
NTSA0XV103□E1B0	10	3900 ±1%	0.46	21	2.1	7	-40 to 125
NTSA0WB203□E1B0	20	4050 ±1%	0.31	21	2.1	7	-40 to 125
NTSA0WC303□E1B0	30	4100 ±1%	0.26	21	2.1	7	-40 to 125
NTSA0WD503□E1B0	50	4150 ±1%	0.20	21	2.1	7	-40 to 125
NTSA0WF104□E1B0	100	4250 ±1%	0.14	21	2.1	7	-40 to 125

A blank column is filled with resistance tolerance codes. (F: ±1%, E: ±3%)

Taping type of part numbers with "N6A0" is available. (Lead spacing=5mm)

The order quantity should be an integral multiple of the "Minimum Quantity" shown in the "Package" page.

Lead-Coating Type

■ Features

1. Electric insulation on lead wire
2. Excellent bending resistance due to suitable hardness of surface coating
3. Easy handling due to most suitable hardness of surface of coating
4. Measurement accuracy of ± 1 (degree C) or less in the range from -40 to +70 (degree C)

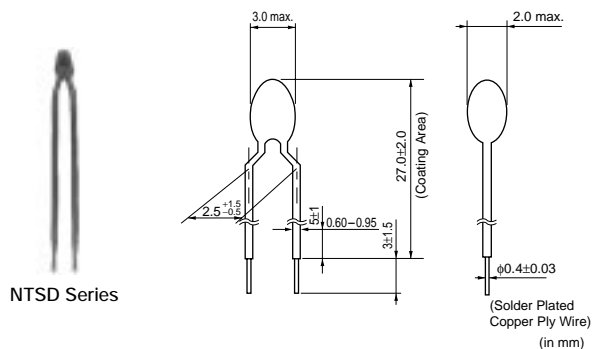
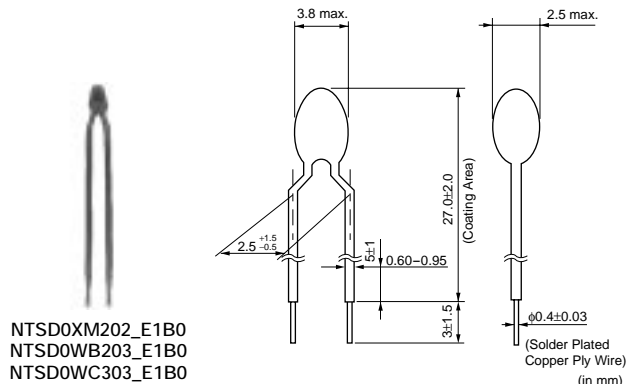

Part Number	Resistance (25°C) (k ohm)	B-Constant (25-50°C) (K)	Permissible Operating Current (25°C) (mA)	Rated Electric Power (25°C) (mW)	Typical Dissipation Constant (25°C) (mW/°C)	Thermal Time Constant (25°C)(s)	Operating Temperature Range (°C)
NTSD0XM202□E1B0	2.0	3500 ±1%	1.05	21	2.1	7	-40 to 125
NTSD0XR502□E1B0	5.0	3700 ±1%	0.68	21	2.1	7	-40 to 125
NTSD0XH103□E1B0	10	3380 ±1%	0.38	15	1.5	7	-40 to 125
NTSD0XV103□E1B0	10	3900 ±1%	0.46	21	2.1	7	-40 to 125
NTSD0WB203□E1B0	20	4050 ±1%	0.31	21	2.1	7	-40 to 125
NTSD0WC303□E1B0	30	4100 ±1%	0.26	21	2.1	7	-40 to 125
NTSD0WD503□E1B0	50	4150 ±1%	0.20	21	2.1	7	-40 to 125
NTSD0WF104□E1B0	100	4250 ±1%	0.14	21	2.1	7	-40 to 125

A blank column is filled with resistance codes. (F: $\pm 1\%$, E: $\pm 3\%$)

The order quantity should be an integral multiple of the "Minimum Quantity" shown in the "Package" page.

■ Temperature Tolerance-Temperature Characteristics

Resistance Tolerance $\pm 1\%$ Type

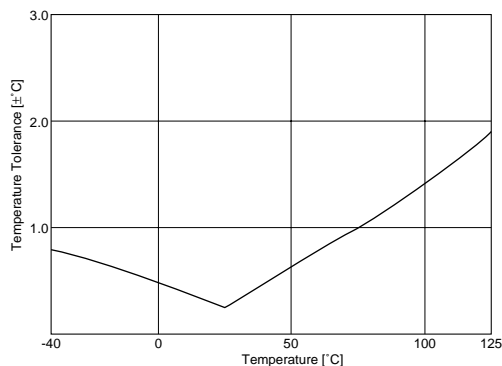

for Temperature Sensor Temperature Characteristics (Reference Value)

Temp. (°C)	NTS□0XM202F type			NTS□0XR502F type			NTS□0XH103F type			NTS□0XV103F type		
	Resistance (kΩ)			Resistance (kΩ)			Resistance (kΩ)			Resistance (kΩ)		
	Low	Center	High	Low	Center	High	Low	Center	High	Low	Center	High
-40	42.859	44.657	46.526	118.390	123.484	128.781	188.021	195.652	203.573	332.325	347.808	363.977
-35	32.249	33.505	34.807	88.747	92.295	95.975	142.788	148.171	153.741	238.323	248.591	259.275
-30	24.504	25.388	26.302	67.127	69.614	72.185	109.522	113.347	117.294	173.098	179.973	187.102
-25	18.777	19.402	20.046	51.112	52.860	54.662	84.823	87.559	90.374	127.191	131.832	136.629
-20	14.516	14.961	15.417	39.246	40.480	41.748	66.270	68.237	70.255	94.524	97.679	100.930
-15	11.327	11.644	11.969	30.400	31.275	32.172	52.229	53.650	55.104	70.962	73.119	75.334
-10	8.906	9.133	9.365	23.718	24.339	24.975	41.477	42.506	43.557	53.820	55.301	56.817
-5	7.035	7.198	7.363	18.710	19.154	19.607	33.147	33.892	34.651	41.237	42.257	43.299
0	5.600	5.716	5.834	14.831	15.148	15.469	26.678	27.219	27.767	31.878	32.582	33.298
5	4.489	4.571	4.655	11.741	11.964	12.189	21.630	22.021	22.417	24.839	25.324	25.815
10	3.623	3.682	3.741	9.365	9.520	9.677	17.643	17.926	18.210	19.514	19.847	20.183
15	2.946	2.987	3.029	7.526	7.624	7.742	14.472	14.674	14.877	15.453	15.679	15.907
20	2.409	2.437	2.466	6.086	6.160	6.234	11.938	12.081	12.224	12.326	12.478	12.630
25	1.980	2.000	2.020	4.950	5.000	5.050	9.900	10.000	10.100	9.900	10.000	10.100
30	1.632	1.651	1.671	4.034	4.082	4.131	8.217	8.315	8.413	7.971	8.068	8.166
35	1.352	1.371	1.389	3.308	3.354	3.401	6.854	6.948	7.043	6.459	6.552	6.645
40	1.126	1.143	1.161	2.729	2.773	2.816	5.745	5.834	5.923	5.267	5.353	5.440
45	0.942	0.958	0.974	2.259	2.299	2.340	4.834	4.917	5.001	4.320	4.399	4.479
50	0.792	0.807	0.822	1.877	1.914	1.952	4.084	4.161	4.239	3.563	3.635	3.708
55	0.670	0.683	0.697	1.573	1.607	1.641	3.464	3.535	3.607	2.954	3.020	3.086
60	0.569	0.582	0.594	1.325	1.356	1.387	2.949	3.014	3.081	2.462	2.521	2.582
65	0.485	0.497	0.508	1.121	1.149	1.177	2.526	2.586	2.647	2.062	2.115	2.170
70	0.415	0.426	0.436	0.953	0.978	1.003	2.173	2.228	2.283	1.736	1.783	1.832
75	0.358	0.367	0.377	0.811	0.834	0.857	1.875	1.925	1.976	1.467	1.510	1.553
80	0.309	0.318	0.326	0.693	0.714	0.734	1.623	1.669	1.715	1.245	1.284	1.323
85	0.268	0.276	0.284	0.594	0.612	0.631	1.411	1.452	1.495	1.061	1.096	1.131
90	0.233	0.240	0.247	0.510	0.527	0.544	1.230	1.268	1.307	0.908	0.939	0.971
95	0.203	0.210	0.216	0.441	0.456	0.471	1.075	1.110	1.145	0.781	0.808	0.837
100	0.178	0.183	0.189	0.383	0.396	0.410	0.942	0.974	1.006	0.674	0.698	0.724
105	0.156	0.161	0.166	0.333	0.345	0.358	0.829	0.858	0.888	0.583	0.605	0.628
110	0.137	0.142	0.147	0.291	0.302	0.313	0.732	0.758	0.785	0.507	0.527	0.547
115	0.121	0.125	0.130	0.255	0.264	0.275	0.647	0.671	0.696	0.442	0.460	0.479
120	0.107	0.111	0.115	0.223	0.232	0.241	0.574	0.596	0.619	0.386	0.403	0.420
125	0.096	0.099	0.103	0.197	0.205	0.213	0.511	0.531	0.552	0.339	0.354	0.369

Temp. (°C)	NTS□0WB203F type			NTS□0WC303F type			NTS□0WD503F type			NTS□0WF104F type		
	Resistance (kΩ)			Resistance (kΩ)			Resistance (kΩ)			Resistance (kΩ)		
	Low	Center	High	Low	Center	High	Low	Center	High	Low	Center	High
-40	700.008	733.007	767.485	1097.262	1149.500	1204.104	1859.709	1948.575	2041.484	4059.035	4256.752	4463.654
-35	502.881	524.831	547.685	785.054	819.651	855.688	1328.527	1387.289	1448.506	2876.261	3005.888	3141.042
-30	365.460	380.184	395.462	568.281	591.391	615.380	960.265	999.456	1040.143	2062.776	2148.514	2237.591
-25	267.924	277.845	288.106	415.020	430.529	446.573	702.528	728.895	756.177	1497.800	1555.020	1614.264
-20	198.531	205.260	212.196	306.393	316.870	327.672	519.195	537.039	555.440	1098.895	1137.312	1176.955
-15	149.036	153.642	158.374	229.194	236.337	243.678	387.052	399.167	411.621	813.431	839.314	865.934
-10	112.855	116.016	119.254	172.958	177.842	182.864	291.216	299.469	307.927	607.840	625.338	643.275
-5	85.960	88.125	90.336	131.298	134.630	138.033	220.570	226.186	231.921	457.312	469.127	481.198
0	66.039	67.522	69.032	100.542	102.816	105.131	168.570	172.393	176.285	347.243	355.224	363.353
5	51.154	52.168	53.197	77.635	79.183	80.755	130.250	132.857	135.503	266.643	272.045	277.529
10	39.927	40.617	41.314	60.411	61.460	62.521	101.322	103.089	104.875	206.172	209.803	213.477
15	31.382	31.847	32.315	47.342	48.045	48.754	79.248	80.430	81.621	160.304	162.713	165.141
20	24.843	25.151	25.461	37.369	37.834	38.300	62.423	63.201	63.982	125.545	127.117	128.696
25	19.800	20.000	20.200	29.700	30.000	30.300	49.500	50.000	50.500	99.000	100.000	101.000
30	15.819	16.014	16.210	23.663	23.955	24.240	39.338	39.825	40.315	78.240	79.215	80.193
35	12.718	12.902	13.088	18.972	19.249	19.528	31.458	31.918	32.382	62.232	63.150	64.075
40	10.286	10.457	10.630	15.304	15.560	15.819	25.308	25.733	26.163	49.803	50.649	51.505
45	8.371	8.527	8.686	12.423	12.657	12.894	20.489	20.877	21.270	40.116	40.885	41.664
50	6.851	6.993	7.137	10.142	10.354	10.569	16.683	17.034	17.390	32.503	33.195	33.898
55	5.643	5.771	5.901	8.334	8.525	8.719	13.615	13.929	14.249	26.396	27.014	27.643
60	4.674	4.789	4.906	6.887	7.058	7.232	11.159	11.439	11.725	21.531	22.079	22.639
65	3.889	3.992	4.097	5.717	5.869	6.025	9.236	9.485	9.741	17.740	18.226	18.724
70	3.251	3.343	3.437	4.769	4.905	5.044	7.684	7.906	8.133	14.693	15.124	15.566
75	2.727	2.809	2.893	3.992	4.113	4.237	6.417	6.614	6.816	12.217	12.598	12.990
80	2.298	2.371	2.446	3.356	3.463	3.574	5.383	5.558	5.738	10.205	10.542	10.890
85	1.955	2.020	2.087	2.849	2.945	3.044	4.531	4.686	4.846	8.554	8.852	9.160
90	1.671	1.729	1.789	2.430	2.516	2.605	3.829	3.967	4.109	7.200	7.463	7.736
95	1.424	1.476	1.529	2.067	2.143	2.222	3.250	3.373	3.499	6.088	6.321	6.562
100	1.217	1.264	1.312	1.764	1.832	1.903	2.770	2.878	2.991	5.167	5.374	5.588
105	1.044	1.085	1.128	1.510	1.571	1.633	2.368	2.465	2.565	4.401	4.585	4.775
110	0.898	0.935	0.973	1.297	1.350	1.407	2.032	2.118	2.207	3.762	3.925	4.094
115	0.779	0.812	0.847	1.123	1.171	1.222	1.751	1.828	1.908	3.231	3.376	3.527
120	0.679	0.708	0.739	0.976	1.019	1.065	1.514	1.583	1.655	2.785	2.913	3.048
125	0.590	0.617	0.644	0.846	0.886	0.927	1.312	1.374	1.438	2.438	2.520	2.640

for Temperature Sensor Lead Type ⚠Caution/Notice

■ ⚠Caution (Storage and Operating Conditions)

This product is designed for application in an ordinary environment (normal room temperature, humidity and atmospheric pressure).

Do not use under the following conditions because all these factors can deteriorate the product characteristics or cause failures and burn-out.

1. Corrosive gas or deoxidizing gas
(Chlorine gas, Hydrogen sulfide gas, Ammonia gas, Sulfuric acid gas, Nitric oxide gas, etc.)
2. Volatile or flammable gas
3. Dusty conditions
4. Under high or low pressure
5. Wet or humid locations
6. Places with salt water, oils, chemical liquids or organic solvents
7. Strong vibrations
8. Other places where similar hazardous conditions exist

■ ⚠Caution (Others)

Be sure to provide an appropriate fail-safe function on your product to prevent secondary damages that may be caused by the abnormal function or the failure of our product.

■ Notice (Storage and Operating Conditions)

To keep solderability of product from declining, the following storage condition is recommended.

1. Storage condition:
Temperature -10 to +40 degree C
Humidity less than 75%RH (not dewing condition)
2. Storage term:
Use this product within 6 months after delivery by first-in and first-out stocking system.
3. Handling after unpacking:
After unpacking, reseal product promptly or store it in a sealed container with a drying agent.
4. Storage place:
Do not store this product in corrosive gas (sulfuric acid gas, chlorine gas, etc.) or in direct sunlight.

■ Notice (Rating)

Use this product within the specified temperature range.

Higher temperature may cause deterioration of the characteristics or the material quality of this product.

■ Notice (Soldering and Mounting)

1. Be sure that the preheat-up does not melt the soldering of this product. Excessive heat may cause failure to open, short or insulation break down.
2. Do not touch the body with soldering iron.
The soldering point should be min. 5mm away from the root of lead wire.

for Temperature Sensor Lead Type ⚠Caution/Notice

■ Notice (Handling)

1. The ceramic element of this product is fragile, and care must be taken not to load an excessive press-force or not to give a shock at handling. Such forces may cause cracking or chipping.
2. Do not apply an excessive force to the lead. Otherwise, it may cause junction between lead and element to break or crack. Holding element by side lead wire is recommended when lead wire is bent or cut.

for Temperature Sensor Lead Type NTSA/NTSD Series Package

■ Minimum Quantity

Part Number	Minimum Quantity (pcs.)	
	Ammo Pack	Bulk
NTSA	3000	100
NTSD	-	100

■ Taping Dimensions (NTSA Series)

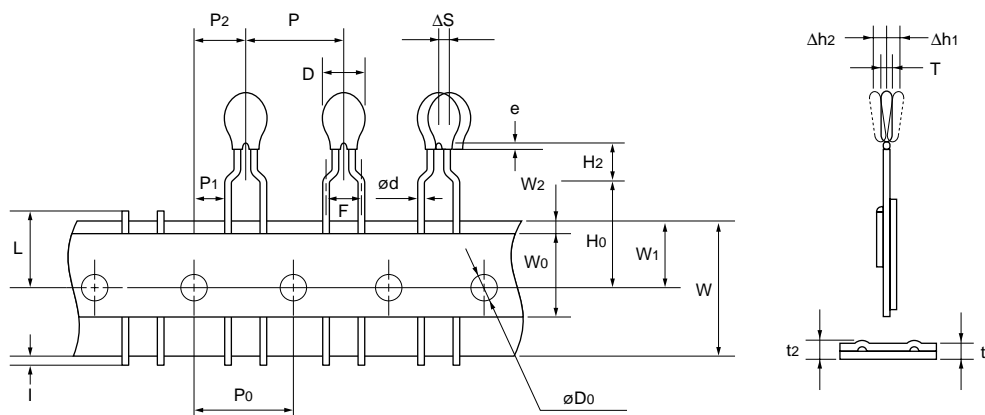

Item	Code	Dimensions (mm)
Pitch of Component	P	12.7
Pitch of Sprocket Hole	P0	12.7±0.3
Lead Spacing	F	5.0+0.8/-0.2
Lead Length from Hole Center to Component Center	P2	6.35±1.3
Lead Length from Hole Center to Lead	P1	3.85±0.8
Body Diameter	D	3.5 max.
Deviation along Tape, Left or Right	ΔS	0±2.0
Carrier Tape Width	W	18.0±0.5
Position of Sprocket Hole	W1	9.0±0.5
Lead Distance between Reference and Bottom Planes	H0	16.0±1.0
Height of Component	H2	4.0 max.
Overflow of Lead	l	+0.5 to -1.0
Diameter of Sprocket Hole	D0	4.0±0.1
Lead Diameter	d	0.50±0.03
Total Tape Thickness	t1	0.6±0.3
Total Thickness, Tape and Lead Wire	t2	1.6 max.
Deviation across Tape	Δh1, Δh2	1.0 max.
Portion to Cut in Case of Defect	L	11.0+0/-2.0
Hole Down Tape Width	W0	11.0 min.
Hole Down Tape Position	W2	1.5±1.5
Coating Extension on Lead	e	Up to the crimp point
Thickness	T	2.6 max.

(in mm)

NTC Thermistors



for Inrush Current Suppression Lead Type

This product effectively suppresses surge current which are generated when switching power regulators or similar switches are turned on.

■ Features

1. Lead is not contained in the ceramic element, the terminations, the solder for inner connection and the coating resin.
2. Most suitable for power supplies of less than 100W.
3. Excellent recovery characteristics due to resin coating with excellent heat characteristics
4. Highly reliable

■ Applications

1. Switching power supplies
2. CRT monitors
3. Color televisions
4. VCR-Power supplies
5. Other power circuits



NTPAN/NTPAJ Series

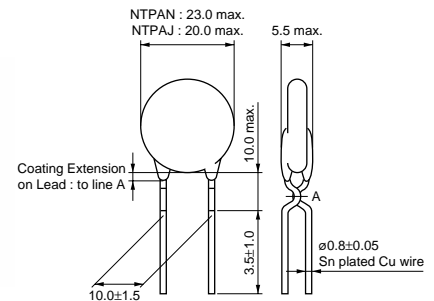

(in mm)



NTPAD/NTPAA Series

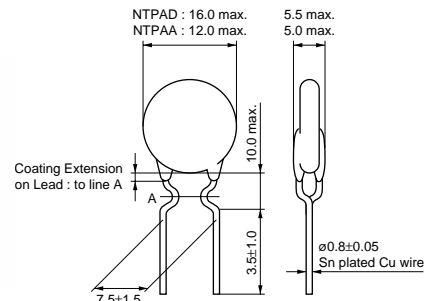

(in mm)



NTPA7/NTPA9 Series

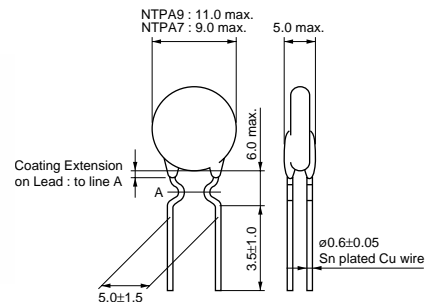

(in mm)

Part Number	Resistance (25°C) (ohm)	Permissible Max. Current (25°C) (A)	Permissible Max. Current (55°C) (A)	Thermal Time Constant (25°C)(s)	Thermal Dissipation Constant (mW/°C)	Permissible Electrolytic Capacitor (µF)
NTPAN3R0LDKB0	3.0 ±15%	5.4	4.7	135	26.8	8600 at 100V
NTPAN4R0LDKB0	4.0 ±15%	4.7	4.1	130	26.8	8600 at 100V
NTPAN6R0LDKB0	6.0 ±15%	3.9	3.4	130	26.8	8600 at 100V
NTPAJ4R0LDKB0	4.0 ±15%	4.0	3.5	125	21.8	5000 at 100V
NTPAJ6R0LDKB0	6.0 ±15%	3.4	2.9	125	21.8	5000 at 100V
NTPAJ8R0LDKB0	8.0 ±15%	3.0	2.6	130	21.8	5000 at 100V
NTPAJ100LDKB0	10.0 ±15%	2.6	2.2	130	21.8	5000 at 100V
NTPAD3R9LDNB0	3.9 ±15%	3.3	2.9	65	18.2	2700 at 100V
NTPAD5R1LDNB0	5.1 ±15%	3.0	2.6	85	18.8	2700 at 100V
NTPAD8R0LDNB0	8.0 ±15%	2.7	2.3	65	18.7	2700 at 100V
NTPAD160LDNB0	16.0 ±15%	2.0	1.7	100	19.1	2700 at 100V
NTPAA2R2LDNB0	2.2 ±15%	3.7	3.2	70	13.5	1400 at 100V

Continued on the following page.

Continued from the preceding page.

Part Number	Resistance (25°C) (ohm)	Permissible Max. Current (25°C) (A)	Permissible Max. Current (55°C) (A)	Thermal Time Constant (25°C)(s)	Thermal Dissipation Constant (mW/°C)	Permissible Electrolytic Capacitor (μF)
NTPAA3R9LDNB0	3.9 ±15%	2.7	2.3	70	13.5	1400 at 100V
NTPAA5R1LDNB0	5.1 ±15%	2.5	2.2	70	13.5	1400 at 100V
NTPAA8R2LDNB0	8.2 ±15%	2.0	1.7	70	13.5	1400 at 100V
NTPAA100LDNB0	10.0 ±15%	1.7	1.5	70	13.5	1400 at 100V
NTPA9160LBMB0	16.0 ±15%	1.4	1.2	65	11.6	800 at 100V
NTPA74R0LBMB0	4.0 ±15%	2.3	2.0	40	9.4	700 at 100V
NTPA78R0LBMB0	8.0 ±15%	1.7	1.5	40	9.5	570 at 100V
NTPA7160LBMB0	16.0 ±15%	1.2	1.0	40	9.9	400 at 100V
NTPA7220LBMB0	22.0 ±15%	1.0	0.88	40	9.1	400 at 100V

NTPAD/NTPAA/NTPA7 series are also available on tape.

The order quantity should be an integral multiple of the "Minimum Quantity" shown in the "Package" page.

■ Application Circuit

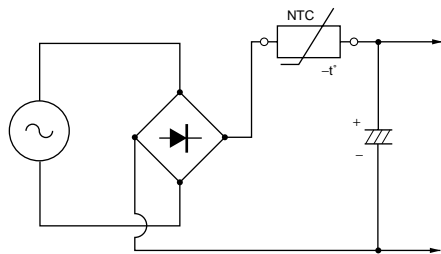

■ Determination of Allowable Current

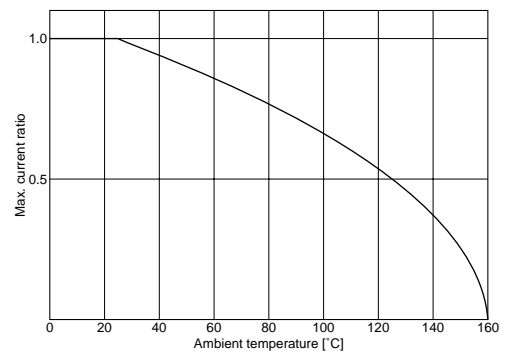

Current-R Ratio (RT/R25) / Current-Temperature Characteristics (Typical)

■ NTPAN3R0L Type

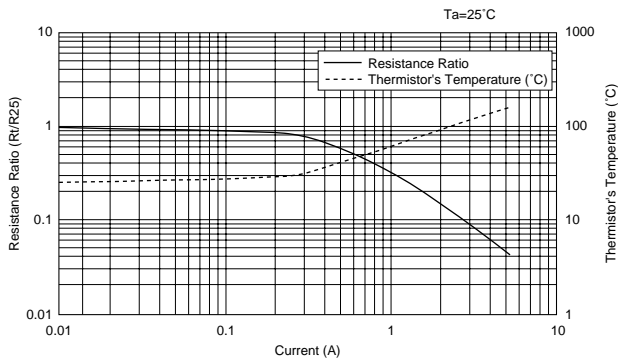

■ NTPAN4R0L Type

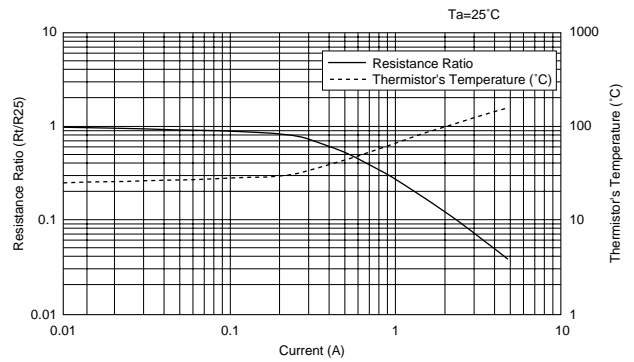

■ NTPAN6R0L Type

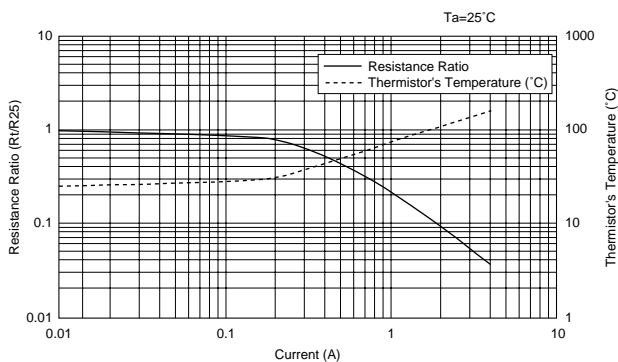

■ NTPAJ4R0L Type

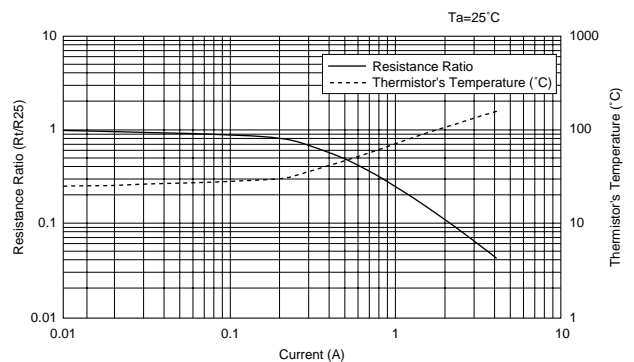

6

■ NTPAJ6R0L Type

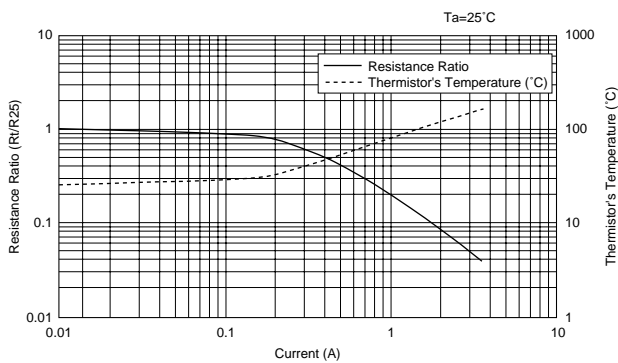

■ NTPAJ8R0L Type

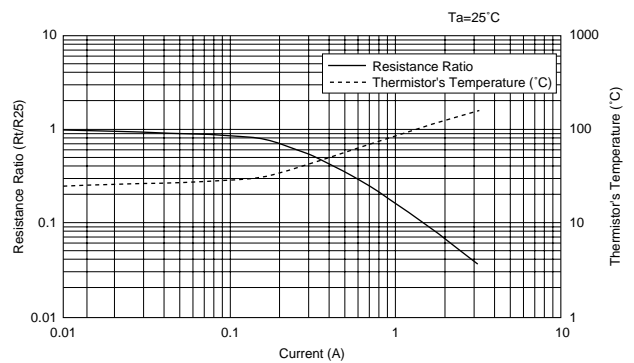

Continued on the following page. ↗

Current-R Ratio (RT/R25) / Current-Temperature Characteristics (Typical)

↳ Continued from the preceding page.

■ NTPAJ100L Type

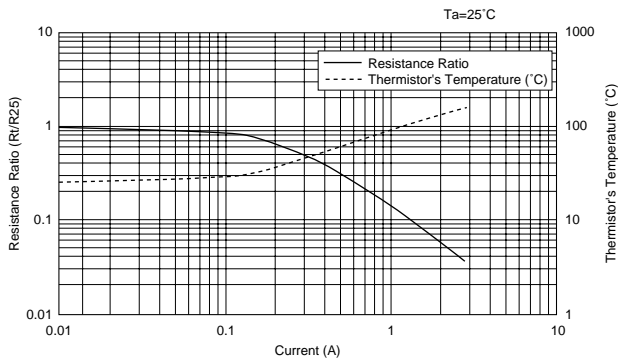

■ NTPAD3R9L Type

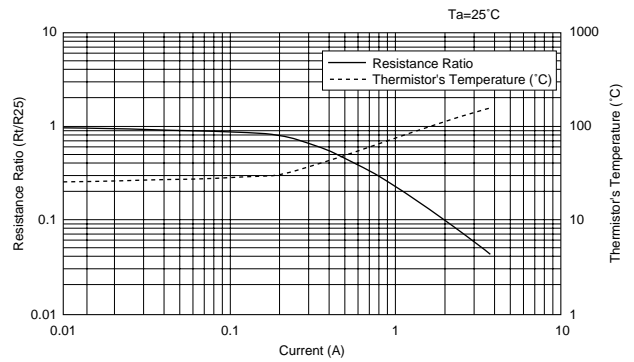

■ NTPAD5R1L Type

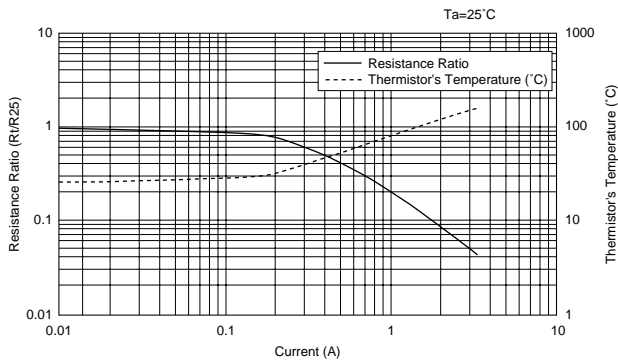

■ NTPAD8R0L Type

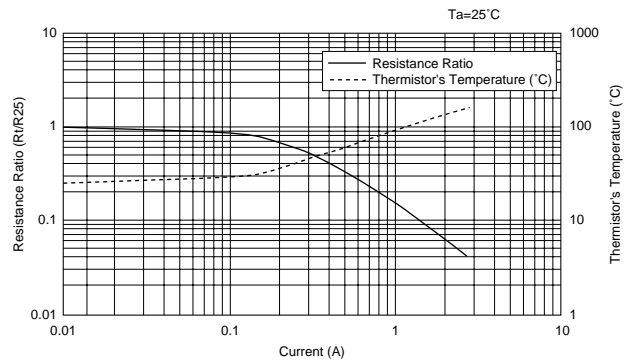

■ NTPAD160L Type

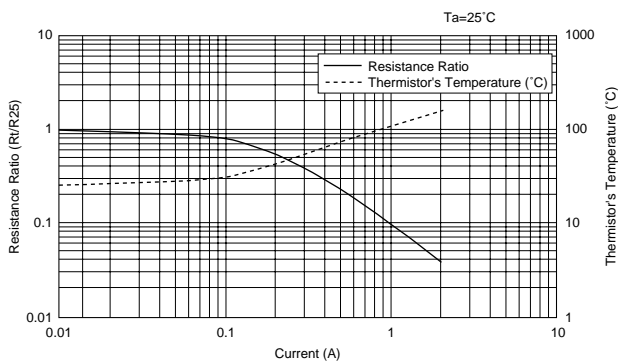

■ NTPAA2R2L Type

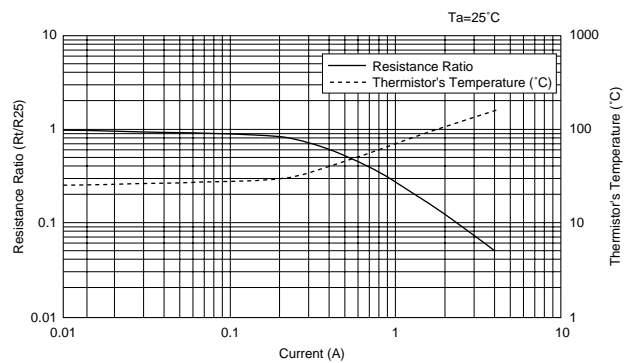

↳ Continued on the following page.

Current-R Ratio (RT/R25) / Current-Temperature Characteristics (Typical)

Continued from the preceding page.

■ NTPAA3R9L Type

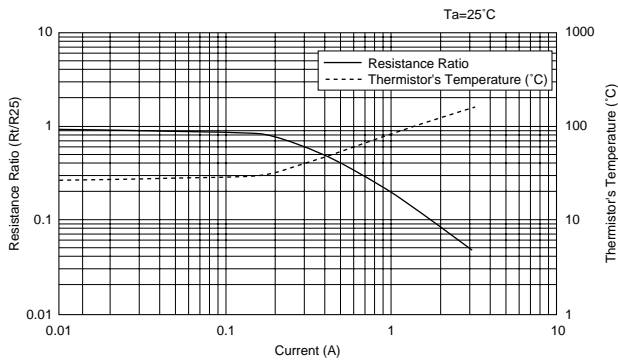

■ NTPAA5R1L Type

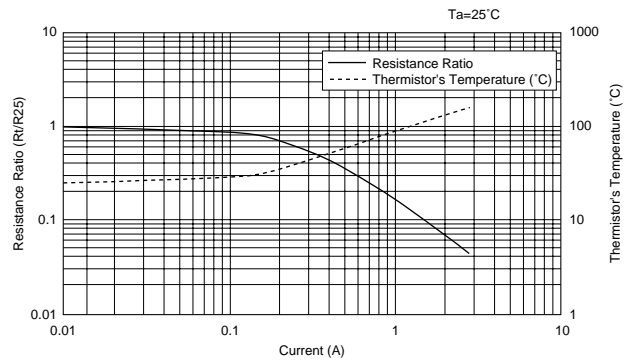

■ NTPAA8R2L Type

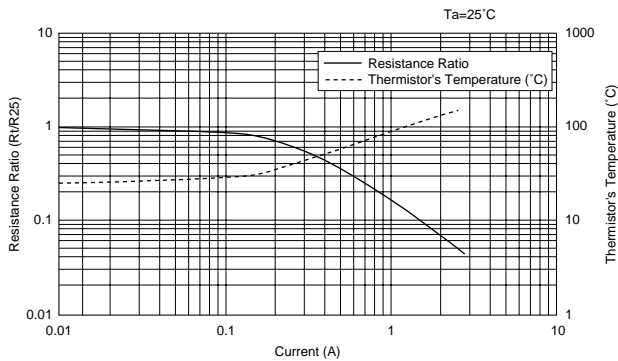

■ NTPAA100L Type

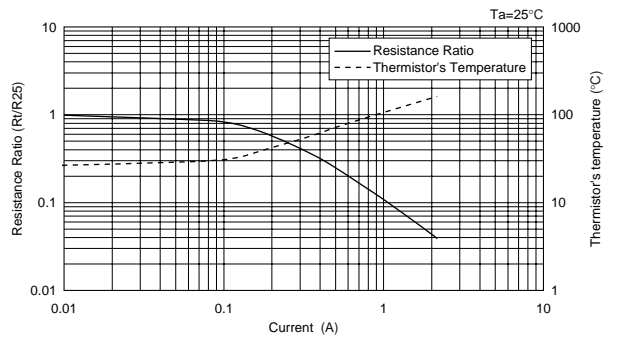

6

■ NTPA9160L Type

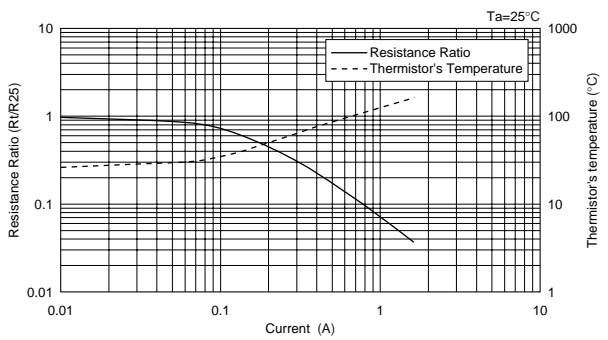

■ NTPA74R0L Type

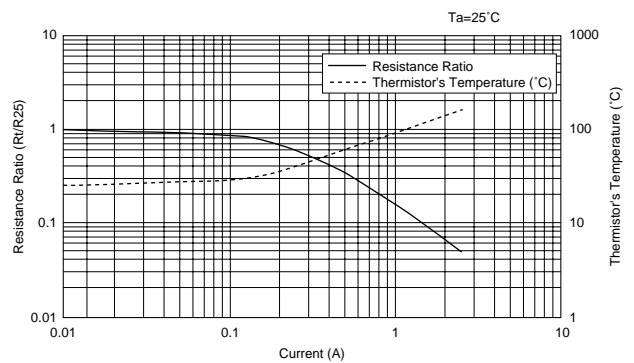

Continued on the following page. ↗

Current-R Ratio (RT/R25) / Current-Temperature Characteristics (Typical)

↳ Continued from the preceding page.

■ NTPA78R0L Type

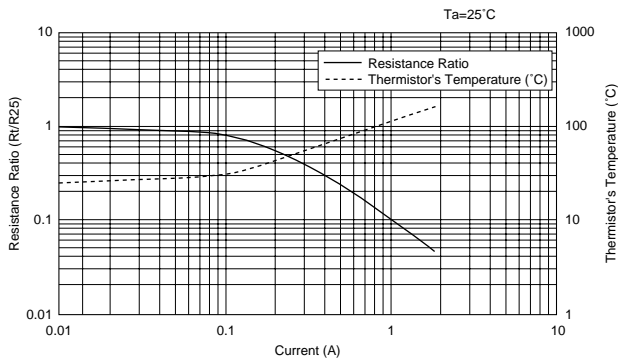

■ NTPA7160L Type

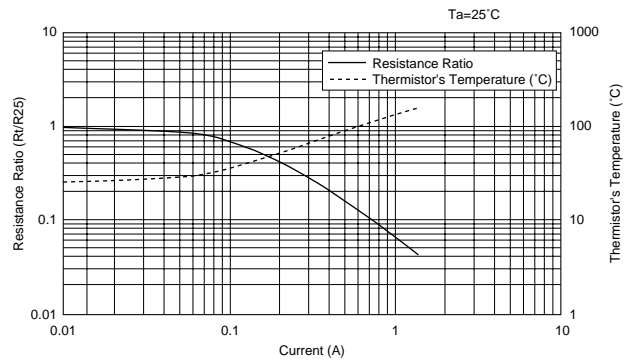

■ NTPA7220L Type

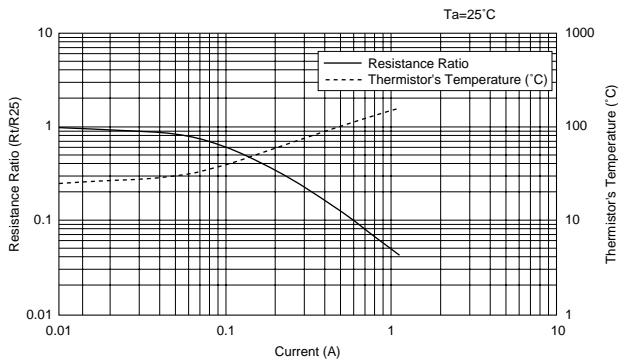

for Inrush Current Suppression Lead Type ⚠️Caution / Notice

■ ⚠️Caution (Storage and Operating Conditions)

1. This product is designed for the Switching Power Supply with smoothing capacitors.
Other applications of this product may result in fire.
2. Use this product within the specified maximum current. Otherwise it may catch fire in the worst case.
3. Use this product with smoothing capacitor within the specified maximum capacitance value. Otherwise it may catch fire in the worst case.
4. This product is designed for application in an ordinary environment (normal room temperature, humidity and atmospheric pressure).
Do not use under the following conditions because

all these factors can deteriorate the product characteristics cause of failure and burn-out.

- (1) Corrosive gas or deoxidizing gas
(Chlorine gas, Hydrogen sulfide gas, Ammonia gas, Sulfuric acid gas, Nitric oxide gas, etc.)
- (2) Volatile or flammable gas
- (3) Dusty conditions
- (4) Under high or low pressure
- (5) Wet or humid conditions
- (6) Places with salt water, oils, chemical liquids or organic solvents
- (7) Strong vibrations
- (8) Other places where similar hazardous conditions exist

■ ⚠️Caution (Others)

Be sure to provide an appropriate fail-safe function on your product to prevent secondary damages that may be caused by the abnormal function or the failure of our product.

■ Notice (Storage and Operating Conditions)

To keep solderability of product from declining, the following storage condition is recommended.

1. Storage condition:
Temperature -10 to +40 degree C
Humidity less than 75%RH (not dewing condition)
2. Storage term:
Use this product within 6 months after delivery by first-in and first-out stocking system.

3. Handling after unpacking:
After unpacking, reseal product promptly or store it in a sealed container with a drying agent.
4. Storage place:
Do not store this product in corrosive gas (sulfuric acid gas, chlorine gas, etc.) or in direct sunlight.

■ Notice (Rating)

Use this product within the specified temperature range.

Higher temperature may cause deterioration of the characteristics or the material quality of this product.

■ Notice (Soldering and Mounting)

1. Be sure that the preheat-up does not melt the soldering of this product. Excessive heat may cause failure to open, short or insulation break down.
2. Do not touch the body with soldering iron.
The soldering point should be min. 5mm away from the root of lead wire.

for Inrush Current Suppression Lead Type ⚠Caution / Notice

■ Notice (Handling)

1. When this product is operated, temperature of some area may be about 160 (degree C).
Use proper surrounding parts and material which withstand such temperature. If they are inadequate and kept at high temperature for long time, they may be deteriorated or may produce harmful gas. And, such harmful gas may deteriorate the element of this product.
2. The ceramic element of this product is fragile, and

care must be taken not to load an excessive press-force or not to give a shock at handling. Such forces may cause cracking or chipping to the element.

3. Do not apply an excessive force to the lead wire. Otherwise, it may cause break off junction between lead wire and element, or may crack element. So, fix lead wire of element side when lead wire is bent or cut.

■ Notice (Others)

1. This products need sufficient cool off time to recover high resistance. Repeated ON-OFF may cause over specified current rating.
Make sure inrush current do not exceed the specified ratings even at the worst condition. (maximum ambient temperature and the shortest off time.)
2. The resin coating of this product does not guarantee insulating. Keep an adequate insulating distance to surrounding parts.

for Inrush Current Suppression Lead Type Package

■ Minimum Quantity

Part Numbers	Minimum Quantity (pcs.)	
	Ammo pack	Bulk
NTPA7	1000	100
NTPA9	1000	100
NTPAA	750	100
NTPAD	400	100
NTPAJ	-	100
NTPAN	-	100

■ NTPAD/NTPAA Series

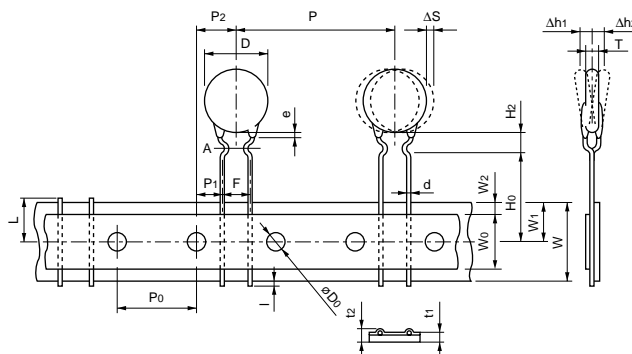

Item	Code	Dimensions (mm)
Pitch of Component	P	30.0
Pitch of Sprocket Hole	P ₀	15.0±0.3
Lead Spacing	F	7.5±0.5
Length from Hole Center to Component	P ₂	7.5±1.5
Length from Hole Center to Lead	P ₁	3.75±1.0
Body Diameter	D	(refer to the table below)
Thickness	T	(refer to the table below)
Deviation along Tape, Left or Right	ΔS	±2.0
Carrier Tape Width	W	18.0±0.5
Position of Sprocket Hole	W ₁	9.0±0.5
Lead Distance between Reference and Bottom Planes	H ₀	16.0±0.5
Height of Component	H ₂	Max. 10.0
Overflow of Lead	l	+0.5 to -6.0
Diameter of Sprocket Hole	D ₀	4.0±0.1
Lead Diameter (Sn-Plated Cu Wire)	d	0.8±0.05
Total Tape Thickness	t ₁	0.6±0.3
Total Thickness, Tape and Lead Wire	t ₂	Max. 2.0
Deviation across Tape	Δh ₁ , Δh ₂	Max. 2.0
Portion to cut in Case of Defect	L	11.0 ⁺⁰ _{-2.0}
Hole Down Tape Width	W ₀	Min. 11.5
Hole Down Tape Position	W ₂	Max. 4.0
Coating Extension on Lead	e	to line A

Type	D	T
NTPAD	16.0 max.	5.5 max.
NTPAA	12.0 max.	5.0 max.

Continued on the following page. ↗

for Inrush Current Suppression Lead Type Package

Continued from the preceding page.

■ NTPA7/NTPA9 Series

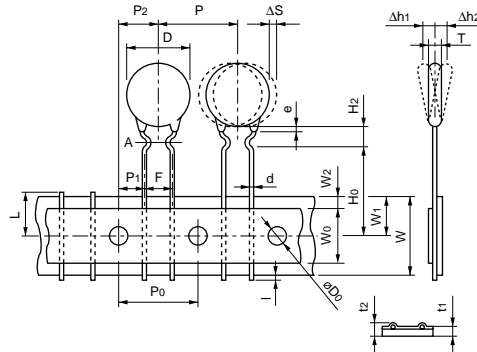

Item	Code	Dimensions (mm)
Pitch of Component	P	12.7
Pitch of Sprocket Hole	P ₀	12.7±0.3
Lead Spacing	F	5.0 ^{+0.8} _{-0.3}
Length from Hole Center to Component	P ₂	6.35±1.3
Length from Hole Center to Lead	P ₁	3.85±0.8
Body Diameter	D	(refer to the table below)
Thickness	T	Max. 5.0
Deviation along Tape, Left or Right	ΔS	±1.5
Carrier Tape Width	W	18.0±0.5
Position of Sprocket Hole	W ₁	9.0 ^{+0.5} _{-0.75}
Lead Distance between Reference and Bottom Planes	H ₀	16.0±1.0
Height of Component	H ₂	Max. 6.0
Overflow of Lead	l	+0.5 to -4.0
Diameter of Sprocket Hole	D ₀	4.0±0.3
Lead Diameter (Sn-Plated Cu Wire)	d	0.6±0.05
Total Tape Thickness	t ₁	0.6±0.3
Total Thickness, Tape and Lead Wire	t ₂	Max. 2.0
Deviation across Tape	Δh ₁ , Δh ₂	Max. 1.5
Portion to cut in Case of Defect	L	11.0 ⁺⁰ _{-2.0}
Hole Down Tape Width	W ₀	Min. 11.0
Hole Down Tape Position	W ₂	Max. 4.0
Coating Extension on Lead	e	to line A

Type	D
NTPA9	11.0 max
NTPA7	9.0 max.

⚠Note:

1. Export Control

⟨For customers outside Japan⟩

Murata products should not be used or sold for use in the development, production, stockpiling or utilization of any conventional weapons or mass-destructive weapons (nuclear weapons, chemical or biological weapons, or missiles), or any other weapons.

⟨For customers in Japan⟩

For products which are controlled items subject to the "Foreign Exchange and Foreign Trade Law" of Japan, the export license specified by the law is required for export.

2. Please contact our sales representatives or product engineers before using the products in this catalog for the applications listed below, which require especially high reliability for the prevention of defects which might directly damage to a third party's life, body or property, or when one of our products is intended for use in applications other than those specified in this catalog.

- | | |
|-----------------------------|---|
| ① Aircraft equipment | ② Aerospace equipment |
| ③ Undersea equipment | ④ Power plant equipment |
| ⑤ Medical equipment | ⑥ Transportation equipment (vehicles, trains, ships, etc.) |
| ⑦ Traffic signal equipment | ⑧ Disaster prevention / crime prevention equipment |
| ⑨ Data-processing equipment | ⑩ Application of similar complexity and/or reliability requirements to the applications listed in the above |

3. Product specifications in this catalog are as of October 2003. They are subject to change or our products in it may be discontinued without advance notice. Please check with our sales representatives or product engineers before ordering. If there are any questions, please contact our sales representatives or product engineers.

4. Please read rating and ⚠CAUTION (for storage, operating, rating, soldering, mounting and handling) in this catalog to prevent smoking and/or burning, etc.

5. This catalog has only typical specifications because there is no space for detailed specifications. Therefore, please approve our product specifications or transact the approval sheet for product specifications before ordering.

6. Please note that unless otherwise specified, we shall assume no responsibility whatsoever for any conflict or dispute that may occur in connection with the effect of our and/or a third party's intellectual property rights and other related rights in consideration of your use of our products and/or information described or contained in our catalogs. In this connection, no representation shall be made to the effect that any third parties are authorized to use the rights mentioned above under licenses without our consent.

7. No ozone depleting substances (ODS) under the Montreal Protocol are used in our manufacturing process.