

Ceramic Resonators (CERALOCK®)

CERAMIC RESONATORS (CERALOCK®)

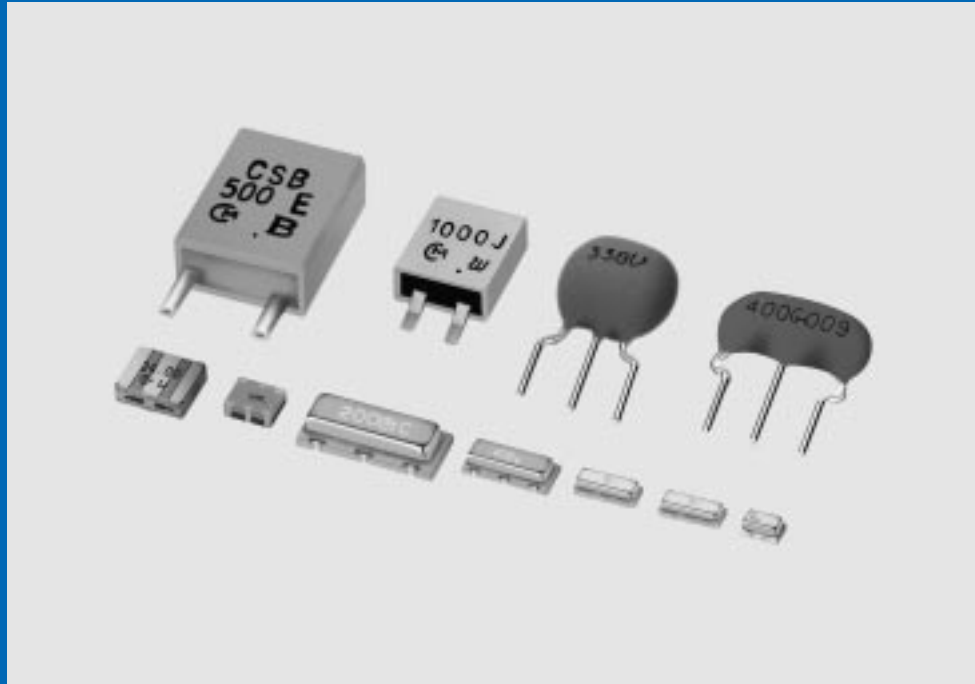

muRata *Innovator
in Electronics*

Murata
Manufacturing Co., Ltd.

Cat.No.P16E-14

CONTENTS

CERALOCK® and "CERALOCK" in this catalog are the trademarks of Murata Manufacturing Co., Ltd.

Part Numbering	2
1 Chip Type Three-Terminals CSTCC/E/G/R/V/W Series	3
2 Chip Type Two-Terminals CSACV/W Series	7
MHz Chip Type Notice	9
MHz Chip Type CSTC Series Packaging	12
MHz Chip Type CSAC Series Packaging	14
3 Lead Type Three-Terminals CSTLS Series	15
4 Lead Type Two-Terminals CSALS Series	17
MHz Lead Type Notice	19
MHz Lead Type CSTLS Series Packaging	20
MHz Lead Type CSALS Series Packaging	22
5 Chip Type Two-Terminals CSBFB Series	23
● kHz Chip Type CSBFB_J 430-519kHz Notice (Soldering and Mounting)	25
● kHz Chip Type CSBFB_J 700-1250kHz Notice (Soldering and Mounting)	26
6 Lead Type Two-Terminals CSBLA Series	27
kHz Lead Type Notice	29
kHz Type Notice	30
kHz Type Packaging	31
Application Circuits Utilizing	32

1

2

3

4

5

6

● Part Numbering

CERALOCK® (MHz)

(Global Part Number)

CS	T	CV	16M0	X53	***	-R0
①	②	③	④	⑤	⑥	⑦

① Product ID

Product ID	
CS	Ceramic Resonators

② Frequency/Capacitance

Code	Frequency/Capacitance
A	MHz No capacitance built-in
T	MHz Built-in Capacitance

③ Structure/Size

Code	Structure/Size
LA	Lead Type
LS	Round Lead Type
CC	Cap Chip Type
CR/CE/CG	Small-cap Chip Type
CV	Monolithic Chip Type
CW	Small Monolithic Chip Type

④ Nominal Center Frequency

Expressed by four-digit alphanumerics. The unit is in hertz (MHz).
Decimal point is expressed by capital letter "M".

⑤ Design

Code	Design
G□□	Thickness Shear mode
T/□□	Thickness Expander mode
X□□	Thickness Expander mode (3rd overtone)

□□ indicates initial frequency tolerance and load capacity.

CERALOCK® (kHz)

(Global Part Number)

CS	B	FB	1M00	J58	***	-R1
①	②	③	④	⑤	⑥	⑦

① Product ID

Product ID	
CS	Ceramic Resonators

② Frequency/Capacitance

Code	Frequency/Capacitance
B	kHz No capacitance built-in

③ Structure/Size

Code	Structure/Size
LA	Two-Terminal Lead Type
FB	SMD Type

④ Nominal Center Frequency

Expressed by four-digit alphanumerics. The unit is in hertz (Hz).
Capital letter "K" following three figures expresses the unit of "kHz".

⑥ Individual Specification

Code	Individual Specification
***	Three-digit alphanumerics express "Individual Specification".

With standard products, "⑥ Individual Specification" is omitted, and "⑦ Package Specification Code" is carried up.

⑦ Packaging

Code	Packaging
-B0	Bulk
-A0	Radial Taping H ₀ =18mm
-A1	Radial Taping H ₀ =16mm
-R0	Plastic Taping ø=180mm
-R1	Plastic Taping ø=330mm

Radial taping is applied to lead type and plastic taping to chip type.

⑤ Design

Code	Design
E□□	Area Expansion mode
J□□	Area Expansion mode (Closed Type)

□□ indicates initial frequency tolerance and load capacitance.

⑥ Individual Specification

Code	Individual Specification
***	Three-digit alphanumerics express "Individual Specification".

With standard products, "⑥ Individual Specification" is omitted, and "⑦ Package Specification Code" is carried up.

⑦ Packaging

Code	Packaging
-B0	Bulk
-R1	Plastic Taping ø=330mm

Ceramic Resonators (CERALOCK®)



Chip Type Three-Terminals CSTCC/E/G/R/V/W Series

Chip "CERALOCK" with built-in load capacitance in an extremely small package.

MURATA's package technology expertise has enabled the development of the Chip "CERALOCK" with built-in load capacitors.

High-density mounting can be realized because of the small package and the elimination of the need for an external load capacitor.

■ Features

1. Oscillation circuits do not require external load capacitors.
2. The series is available in a wide frequency range.
3. The resonators are extremely small and have a low profile.
4. No adjustment is necessary for oscillation circuits.

■ Applications

- Clock oscillators for microprocessors.
- Electronic control circuits for small electronic equipment such as hand held movie.
- Audio-visual applications (Camcorder, Remote Controller, etc.)
- Office automation equipments (DVD, CD-ROM, HDD, FDD, etc.)
- Automotive electronics. (CSTCC_G_A series, CSTCR_G_A series, CSTCE_G_A series, CSTCV_X_Q series)
- Dual Tone Multi Frequency (DTMF) generator for cordless telephones.



CSTCC_G(A)
2.00-3.99MHz

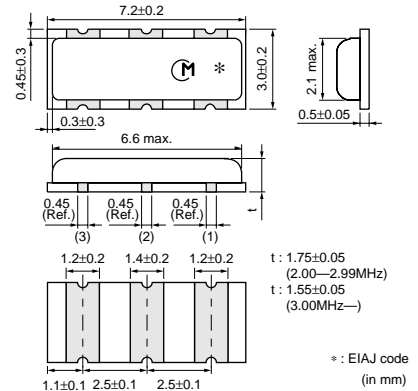

CSTCR_G(A)
4.00-7.99MHz

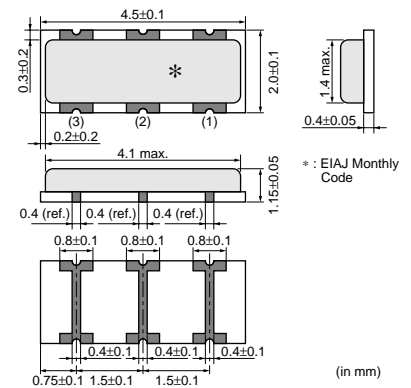

CSTCE_G(A)
8.00-12.50MHz

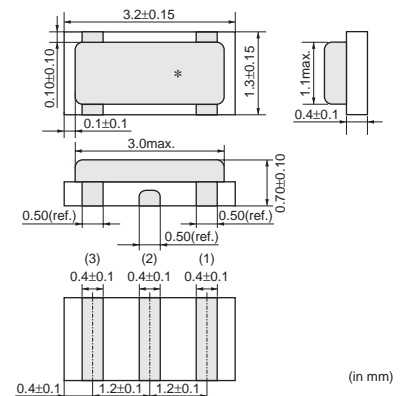

CSTCE_V
12.51-19.99MHz

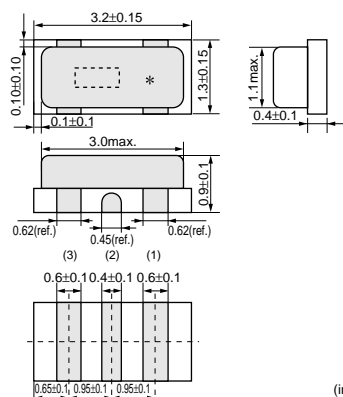

CSTCV_X_Q
14.70-70.00MHz

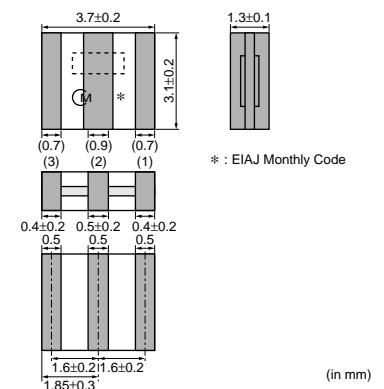

Continued on the following page. ↗

Continued from the preceding page.

1

CSTCW_X
20.00-70.00MHz

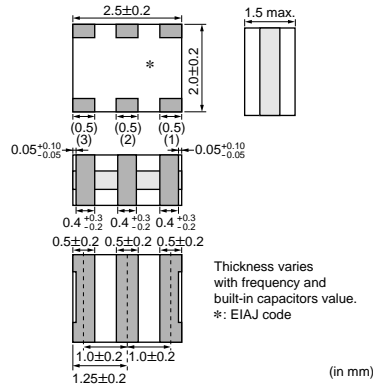

CSTCG_V
20.00-33.86MHz
(Ultra small)

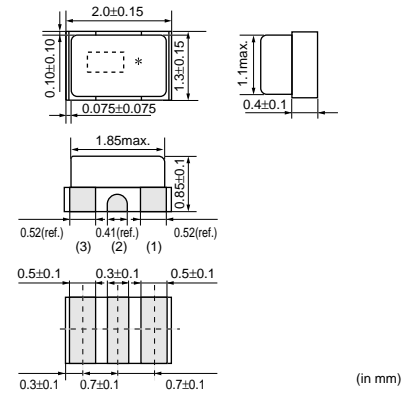

Part Number	Oscillating Frequency (MHz)	Initial Tolerance (%)	Temp.Stability (%)	Temperature Range (°C)	Aging (10 years) (%)	Use
CSTCC_G	2.00 to 3.99	± 0.5	± 0.3	-20 to 80	± 0.3	For consumer electronics
CSTCC_G_A	2.00 to 3.99	± 0.5	± 0.4	-40 to 125	± 0.3	For automotive electronics
CSTCR_G	4.00 to 7.99	± 0.5	± 0.2	-20 to 80	± 0.1	For consumer electronics
CSTCR_G_A	4.00 to 7.99	± 0.5	± 0.3	-40 to 125	± 0.1	For automotive electronics
CSTCE_G	8.00 to 12.50	± 0.5	± 0.2	-20 to 80	± 0.1	For consumer electronics
CSTCE_G_A	8.00 to 12.50	± 0.5	± 0.2	-40 to 125	± 0.1	For automotive electronics
CSTCE_V	12.51 to 19.99	± 0.5	± 0.3	-20 to 80	± 0.3	For consumer electronics
CSTCV_X_Q	14.70 to 70.00	± 0.5	± 0.3	-40 to 125	± 0.1	For automotive electronics
CSTCG_V	20.00 to 33.86	± 0.5	± 0.3	-20 to 80	± 0.3	Ultra small type
CSTCW_X	20.00 to 70.00	± 0.5	± 0.2	-20 to 80	± 0.1	For consumer electronics

Irregular or stop oscillation may occur under unmatched circuit conditions. Please check the actual conditions prior to use.

■ Oscillation Frequency Measuring Circuit

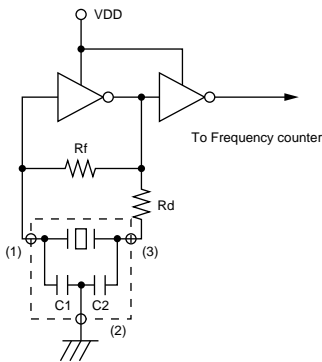

■ Standard Land Pattern Dimensions

CSTCC_G(A)

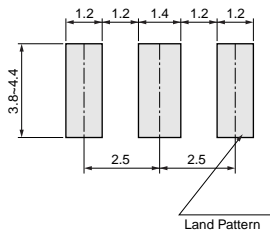

(in mm)

CSTCR_G(A)

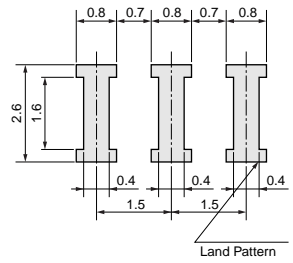

(in mm)

CSTCE_G(A)

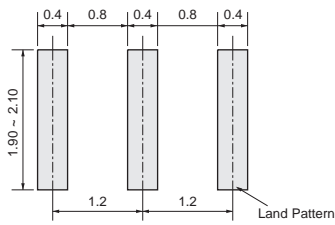

(in mm)

CSTCE_V

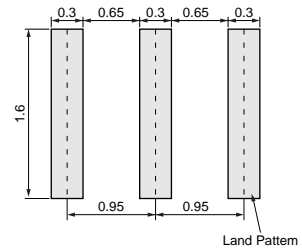

(in mm)

CSTCV_X_Q

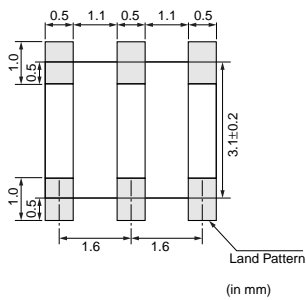

(in mm)

CSTCG_V

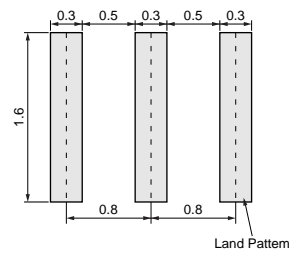

(in mm)

CSTCW_X

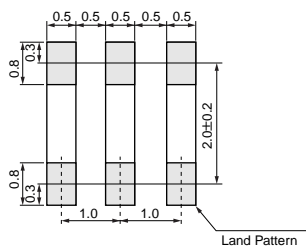

(in mm)

■ Oscillation Frequency Temperature Stability

CSTCC_G

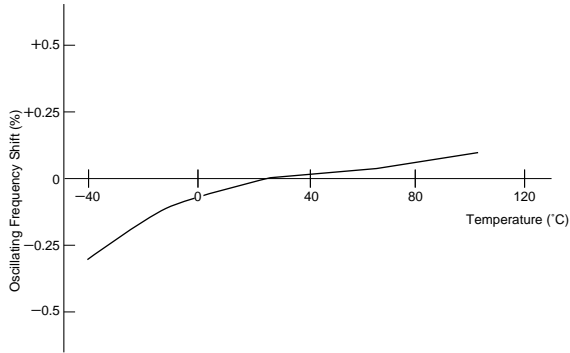

CSTCC_G_A

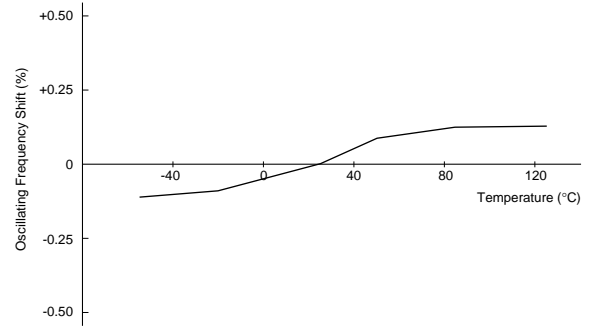

CSTCR_G(A)

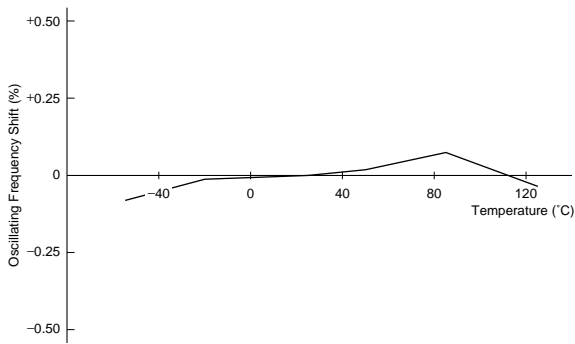

CSTCE_G(A)

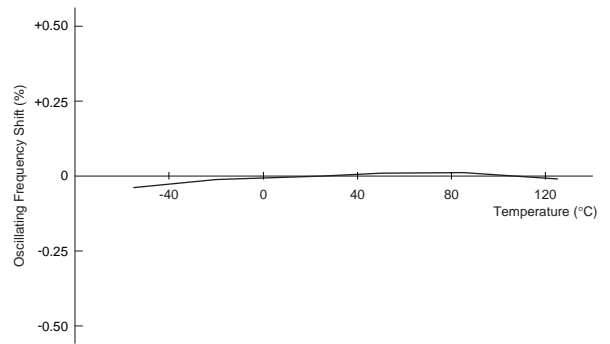

CSTCE_V

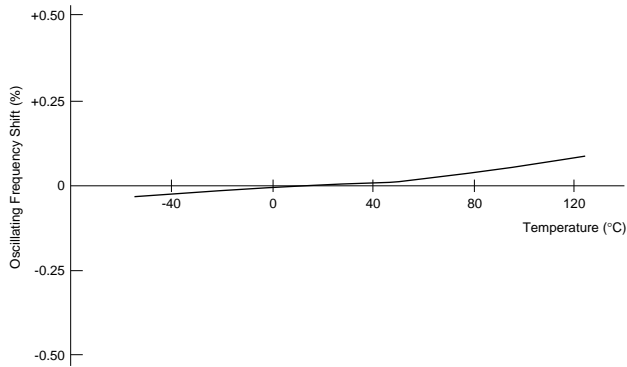

CSTCV_X_Q

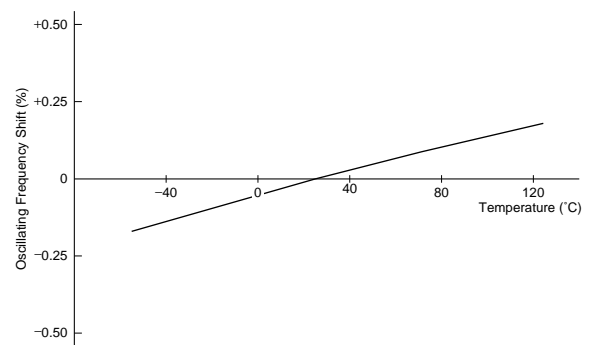

CSTCG_V

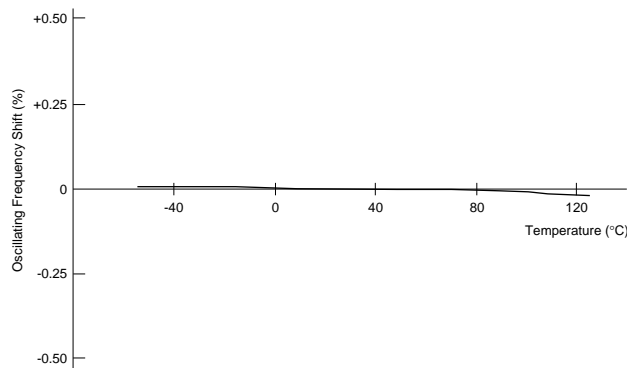

CSTCW_X

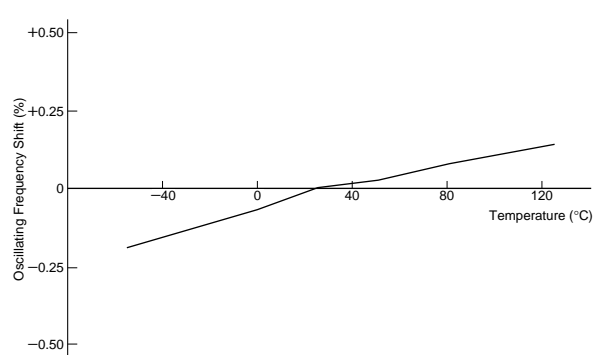

Ceramic Resonators (CERALOCK®)



Chip Type Two-Terminals CSACV/W Series

Wide range of chip "CERALOCK" is now available. This diverse series owes its development to MURATA's package technology expertise and original mass production techniques. It enables high-density mounting and further miniaturization of electronic equipment.

■ Features

1. The series is available in a wide frequency range.
2. The resonators are extremely small and have a low profile. (CSACW series)
3. No adjustment is necessary for oscillation circuits.

■ Applications

- Clock oscillators for microprocessors.
- Electronic control circuits for small electronic equipment.
- Automotive electronics. (CSACV_X_Q series)



CSACV_X_Q
14.70-70.00MHz

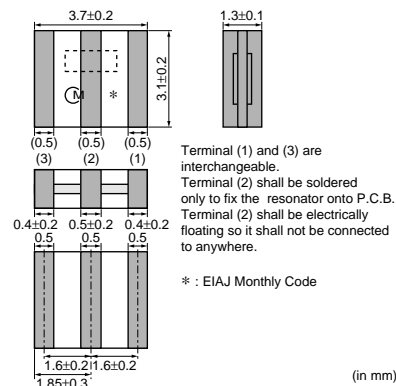

CSACW_X
20.00-70.00MHz

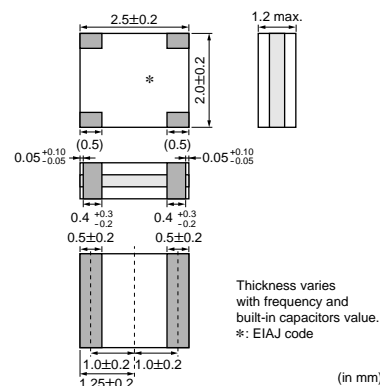

Part Number	Oscillating Frequency (MHz)	Initial Tolerance (%)	Temp.Stability (%)	Temperature Range (°C)	Aging (10 years) (%)	Use
CSACV_X_Q	14.70 to 70.00	±0.5	±0.3	-40 to 125	±0.1	For automotive electronics
CSACW_X_53	20.00 to 24.99	±0.5	±0.2	-20 to 80	±0.1	For consumer electronics
CSACW_X_51	25.00 to 70.00	±0.5	±0.2	-20 to 80	±0.1	For consumer electronics

Irregular or stop oscillation may occur under unmatched circuit conditions. Please check the actual conditions prior to use.

■ Oscillation Frequency Measuring Circuit

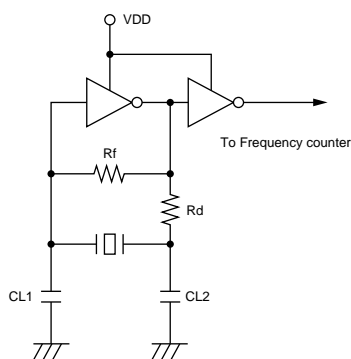

Standard Land Pattern Dimensions

CSACV_X_Q

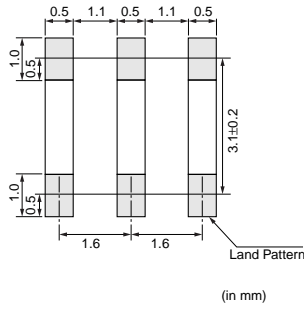

CSACW_X

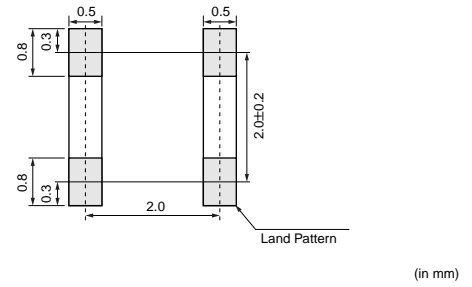

Oscillation Frequency Temperature Stability

CSACV_X_Q

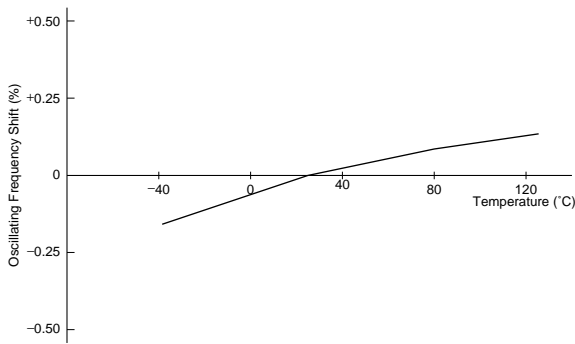

CSACW_X

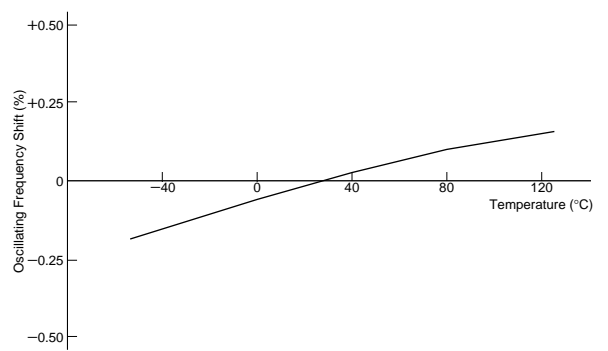

MHz Chip Type Notice (Soldering and Mounting)

1. Soldering Condition

(1) Reflow

One heat stress shown in the right profile is applied to resonator, then being place in natural condition for 1 hour, resonator shall be measure.

1. Pre-heating conditions shall be +140 to +160°C for 60 to 120 seconds. Ascending time up to +150°C shall be longer than 30 second.
2. Heating conditions shall be within 20 seconds at +230°C min., but peak temperature shall be lower than +240°C.

(2) Soldering Iron

Soldering iron of +270±5°C shall be placed 0.5mm above from electrode of resonator. Melting solder through soldering iron shall be applied to electrode for 3±1 seconds, then being place in natural condition for 24 hour, resonator shall be measured.

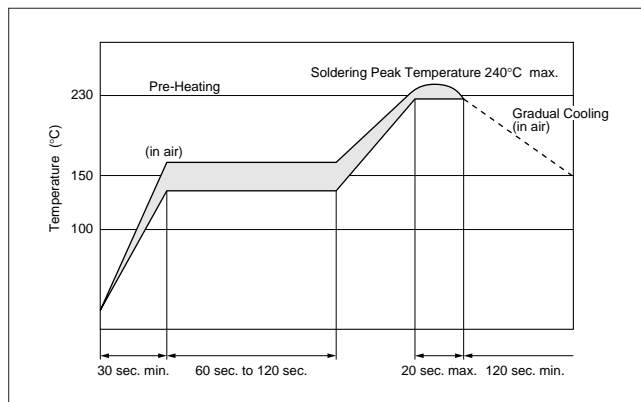

2. Wash

Some series are not withstand washing.
Please check the right list before use.

(1) Cleaning Solvent

HCFC, Isopropanol, Tap water, Demineralized water,
Cleanthrough750H, Pine alpha 100S, Techno care FRW

(2) Temperature Difference : dT *1

$dT \leq 60^\circ\text{C}$ (dT=Component-solvent)

*1 ex. In case the component at +90°C immerses into cleaning solvent at +60°C, then $dT=30^\circ\text{C}$.

(3) Condition

1. Ultrasonic Wash

1 minute max. in above solvent at +60°C max.
(Frequency : 28kHz, Output : 20W/L)

2. Immersion Wash

5 minutes max. in above solvent at +60°C max.

3. Shower or Rinse Wash

5 minutes max. in above solvent at +60°C max.

(4) Drying

5 minutes max. by air blow at +80°C max.

(5) Others

1. Total washing time should be within 10 minutes.
2. Please insure the component is thoroughly evaluated in your application circuit.
3. The component may be damaged if it is washed with chlorine, petroleum, or alkali cleaning solvent.

Series	Wash
CSTCC (Except 2.00-3.49MHz)	Available
CSTCV	Available
CSACV	Available
CSTCR	Not Available
CSTCC (Only 2.00-3.49MHz)	Not Available
CSTCW	Not Available
CSACW	Not Available
CSTCE	Not Available
CSTCG	Not Available

*All automotive types are Available.

MHz Chip Type Notice

■ Notice (Storage and Operating Conditions)

CSTCC_G

Please do not apply excess mechanical stress to the component and terminals at soldering.

The component is recommended with placement machines with employ optical placement capabilities.

The component might be resulted in damage by excessivemechanical force. Please make sure that you have evaluated by using placementmachines before going into mass production. Do not use placement machines whichutilize mechanical positioning. Please contact Murata for details beforehand.

1. CSTCC_G (2.00MHz-3.49MHz)

Conformal coating or washing to the component is not acceptable. Because it is not hermetically sealed.

2. CSTCC_G (3.50MHz-10.0MHz)

Conformal coating of the component is acceptable. However, the resin material, curing temperature, and other process conditions should be evaluated to confirm stable electrical characteristics are maintained.

■ Notice (Storage and Operating Conditions)

CSTCC_G_A/CSTCR_G_A/CSTCE_G_A

Please do not apply excess mechanical stress to the component and terminals at soldering.

Conformal coating of the component is acceptable.

However, the resin material, curing temperature, and other process conditions should be evaluated to confirm stable electrical characteristics are maintained.

The component is recommended with placement machines

with employ optical placement capabilities.

The component might be resulted in damage by excessivemechanical force. Please make sure that you have evaluated by using placementmachines before going into mass production. Do not use placement machines whichutilize mechanical positioning. Please contact Murata for details beforehand.

■ Notice (Storage and Operating Conditions)

CSTCV_X_Q/CSACV_X_Q

Please do not apply excess mechanical stress to the component and terminals at soldering.

Conformal coating of the component is acceptable.

However, the resin material, curing temperature, and other process conditions should be evaluated to confirm stable electrical characteristics are maintained.

The component is recommended with placement machines

which employ optical placement capabilities. In some cases, placement machines which utilize mechanical positioning may apply excessive mechanical force which might result in damage to the ceramic resonator. Please contact Murata before mounting this product using placement machines which use mechanical positioning.

■ Notice (Storage and Operating Conditions)

CSTCW_X/CSACW_X

Please do not apply excess mechanical stress to the component and terminals at soldering.

Conformal coating or washing to the component is not acceptable. Because it is not hermetically sealed.

MHz Chip Type Notice

■ Notice (Storage and Operating Conditions)

CSTCR_G/CSTCE_G/CSTCE_V/CSTCG_V

Please do not apply excess mechanical stress to the component and terminals at soldering.

Conformal coating or washing to the component is not acceptable. Because it is not hermetically sealed.

The component is recommended with placement machines with employ optical placement capabilities.

The component might be resulted in damage by excessivemechanical force. Please make sure that you have evaluated by using placementmachines before going into mass production. Do not use placement machines whichutilize mechanical positioning. Please contact Murata for details beforehand.

■ Notice (Rating)

The component may be damaged if excess mechanical stress is applied.

■ Notice (Handling)

"CERALOCK" may stop oscillating or oscillate irregularly under improper circuit conditions.

MHz Chip Type CSTC Series Packaging

Minimum Quantity

Part Number	Plastic Tape ø180mm	Plastic Tape ø330mm	Bulk	Dimensions
CSTCC_G	2,000	6,000	500	a
CSTCC_G_A	2,000	6,000	500	a
CSTCR_G	3,000	9,000	500	a
CSTCR_G_A	3,000	9,000	500	a
CSTCE_G	3,000	9,000	500	b
CSTCE_G_A	3,000	9,000	500	b
CSTCE_V	3,000	9,000	500	b
CSTCV_X_Q	2,000	6,000	500	a
CSTCW_X	3,000	9,000	500	b
CSTCG_V	3,000	9,000	500	b

The order quantity should be an integral multiple of the "Minimum Quantity" shown above.

(pcs.)

Dimensions of Reel

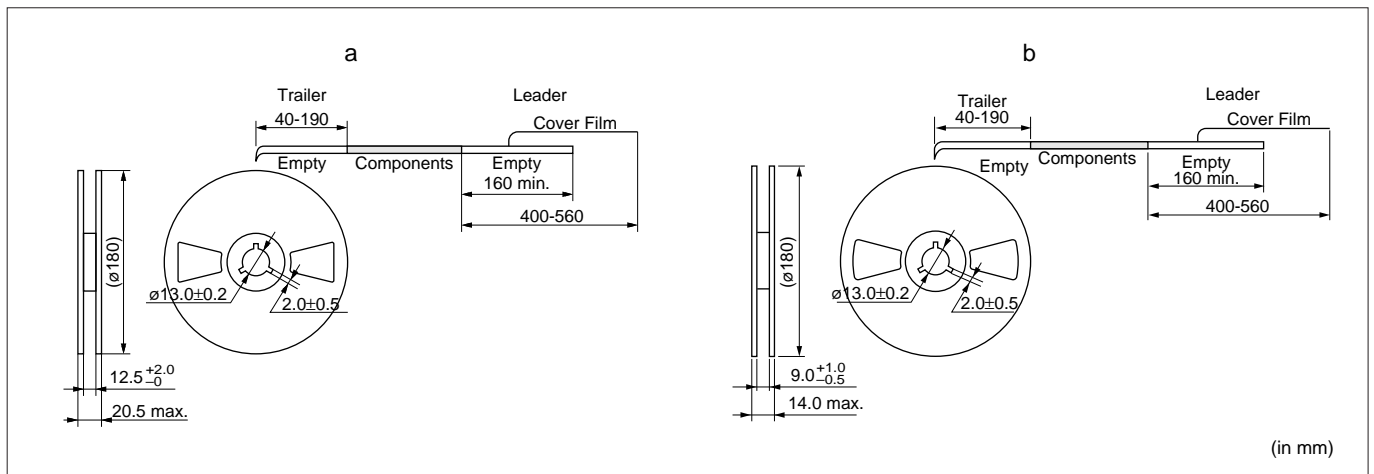

(in mm)

Dimensions of Taping

CSTCC_G(A) less than 3.00MHz

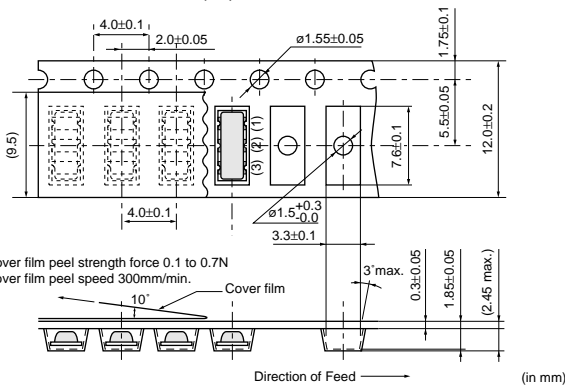

(in mm)

CSTCC_G(A) more than 3.00MHz

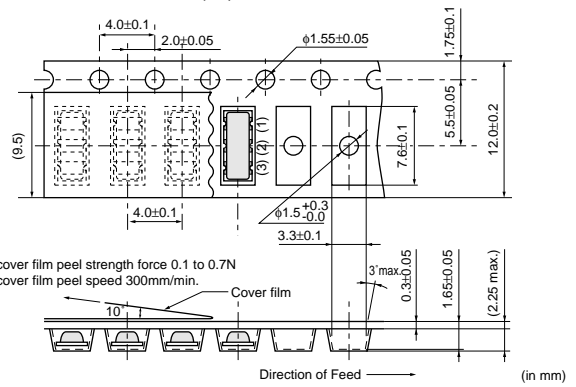

(in mm)

Continued on the following page. ↗

MHz Chip Type CSTC Series Packaging

Continued from the preceding page.

■ Dimensions of Taping

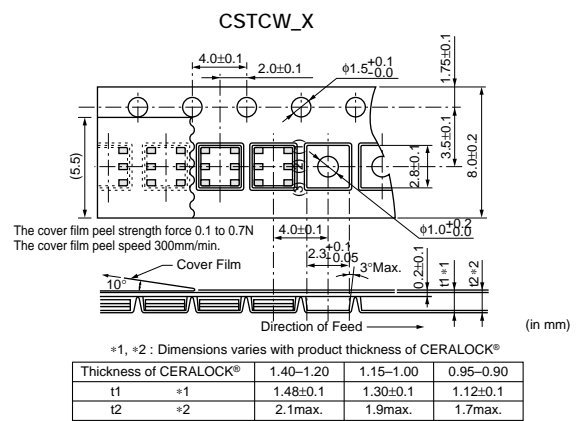
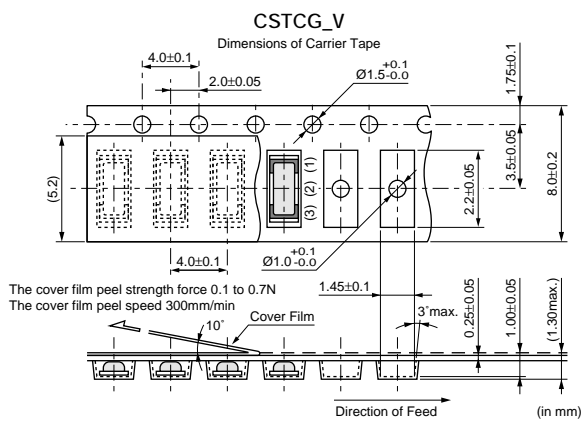
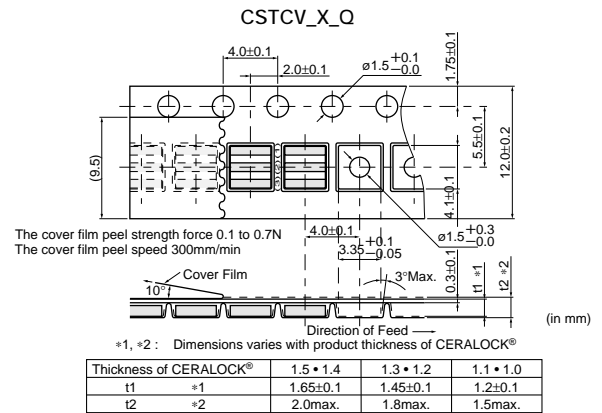
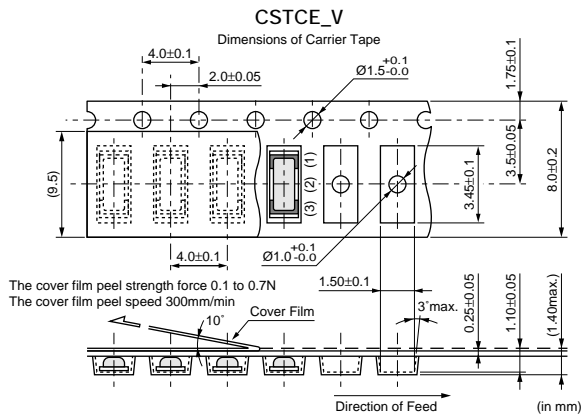
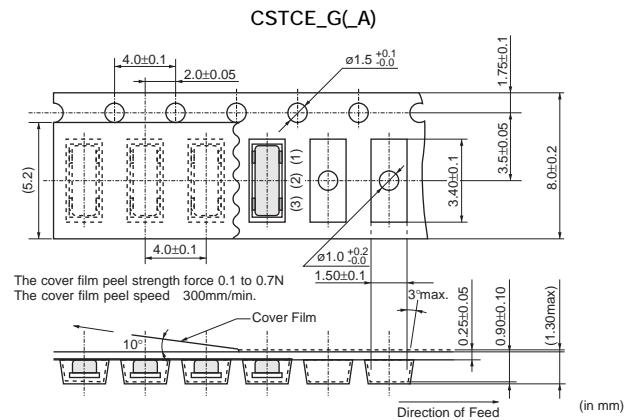
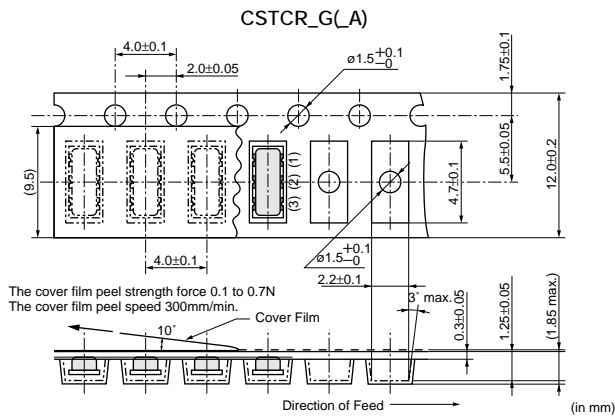

MHz Chip Type CSAC Series Packaging

Minimum Quantity

Part Number	Plastic Tape ø180mm	Plastic Tape ø330mm	Bulk	Dimensions
CSACV_X_Q	2,000	6,000	500	a
CSACW_X	3,000	9,000	500	b

The order quantity should be an integral multiple of the "Minimum Quantity" shown above.

(pcs.)

Dimensions of Reel

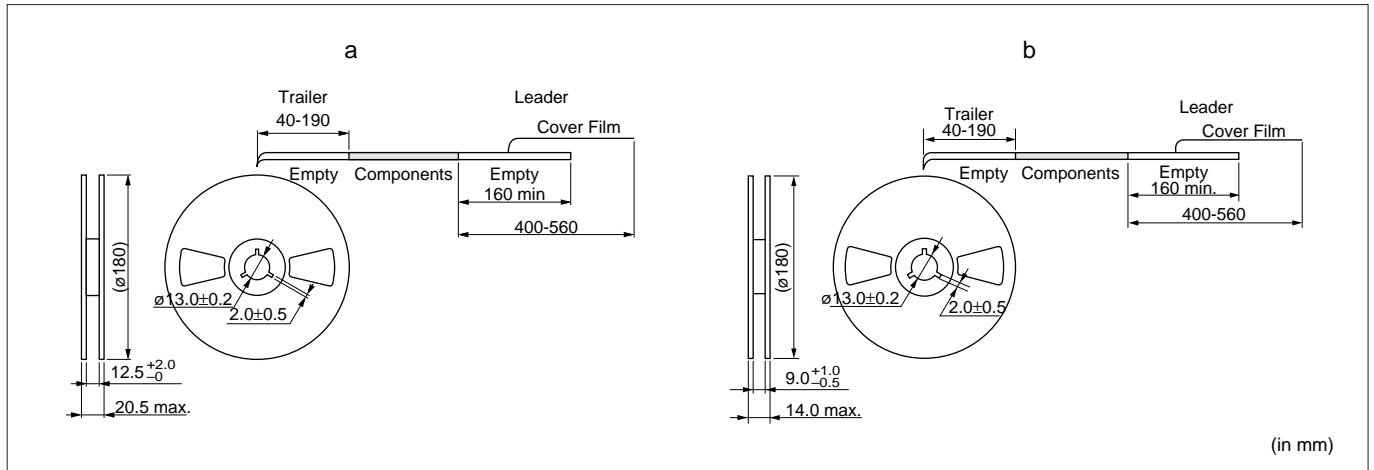

Dimensions of Taping

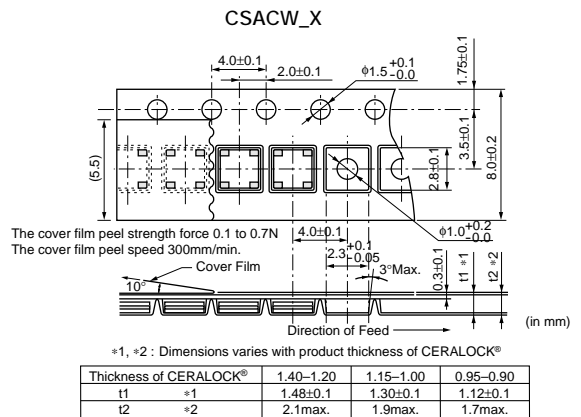
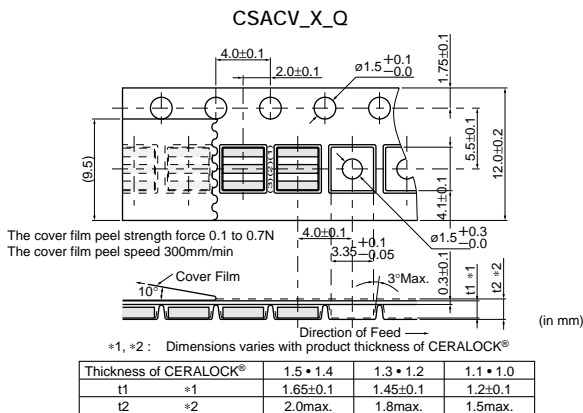

Ceramic Resonators (CERALOCK®)



Lead Type Three-Terminals CSTLS Series

"CERALOCK" with built-in load capacitors.
MURATA's ceramic resonator, "CERALOCK", has been widely applied as the most suitable component for clock oscillators in a broad range of microprocessors. The CSTLS series can be used in the design of oscillation circuits not requiring external load capacitors, enabling both high-density mounting and cost reduction.

■ Features

1. Oscillation circuits do not require external load capacitors.
2. The series is stable over a wide temperature range.
3. The resonators are compact, light weight and exhibit superior shock resistance performance.
4. They enable the design of oscillator circuits requiring no adjustment.
5. The series is inexpensive and available in stable supply.
6. There are some variation of built-in capacitance value to apply various of IC.

■ Applications

- DTMF generators.
- Clock oscillators for microcomputers.
- Remote control units.
- Automated office equipment.

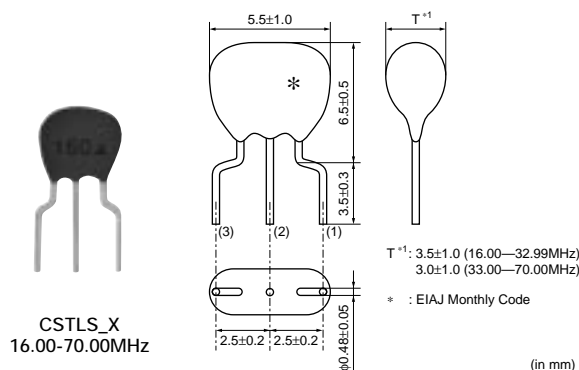
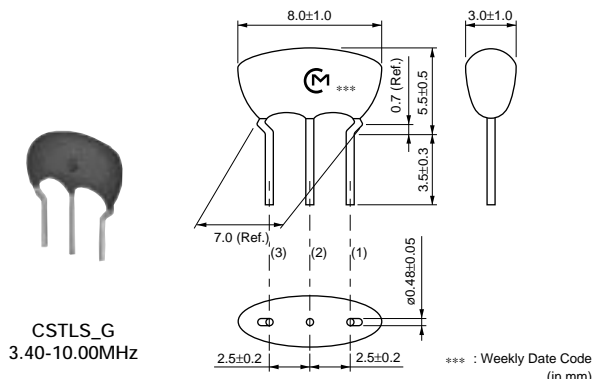

Part Number	Oscillating Frequency (MHz)	Initial Tolerance (%)	Temp.Stability (%)	Temperature Range (°C)	Aging (10 years) (%)	Use
CSTLS_G	3.40 to 10.00	±0.5	±0.2	-20 to 80	±0.2	For consumer electronics
CSTLS_X	16.00 to 70.00	±0.5	±0.2	-20 to 80	±0.2	For consumer electronics

Irregular or stop oscillation may occur under unmatched circuit conditions. Please check the actual conditions prior to use.
The order quantity should be an integral multiple of the "Minimum Quantity" shown in the packaging page.

■ Oscillation Frequency Measuring Circuit

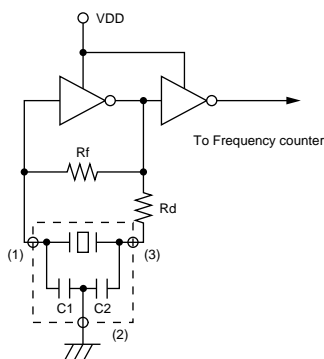

■ Oscillation Frequency Temperature Stability

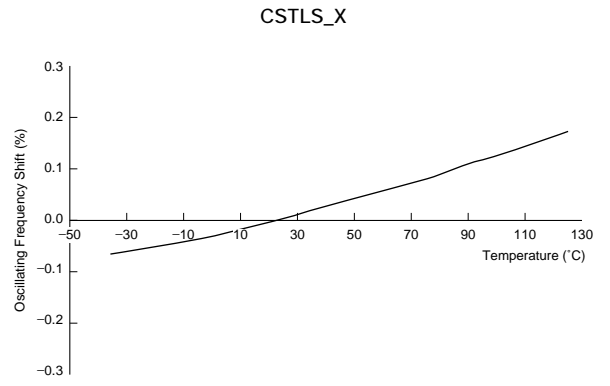
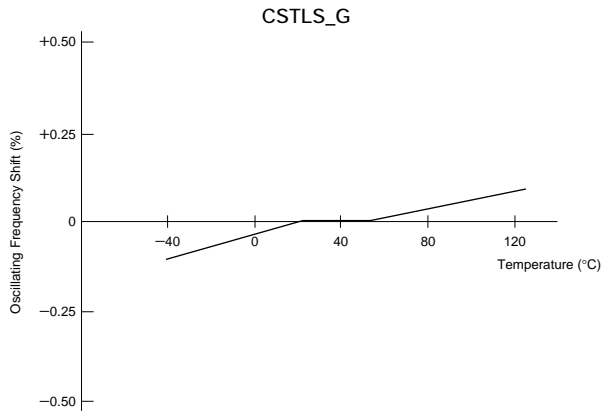

Ceramic Resonators (CERALOCK®)



Lead Type Two-Terminals CSALS Series

"CERALOCK" with two leaded terminals.

The CSALS series ceramic resonator owe their development to MURATA's innovative expert technologies and the application of mass production techniques typically utilized in the manufacture of piezoelectric ceramic components. Because of their high mechanical Q and consistent high quality, CSALS series are ideally suited to microprocessor and remote control unit applications.

In addition, MURATA offers a special "CERALOCK" version suitable for automatic insertion utilizing tape and reel and other packaging forms. For further information, please contact your local MURATA representative office or authorized distributor.

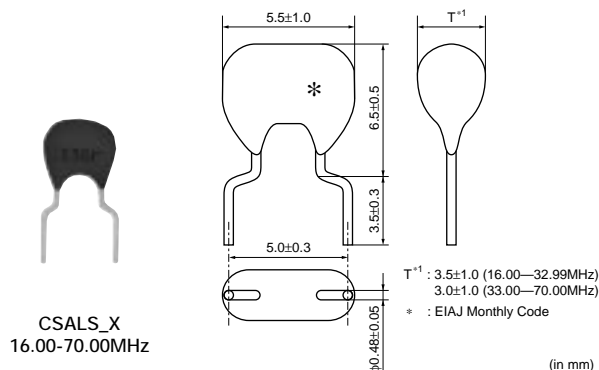

■ Features

1. The series is stable over a wide temperature range and with respect to long-term aging.
2. The series comprises fixed, tuned, solid-state devices.
3. The resonators are miniature and light weight.
4. They exhibit excellent shock resistance performance.
5. Oscillating circuits requiring no adjustment can be designed by utilizing these resonators in conjunction with transistors or appropriate ICs.

■ Applications

- Square-wave and sine-wave oscillator.
- Clock generator for microprocessors.
- Remote control systems.

Part Number	Oscillating Frequency (MHz)	Initial Tolerance (%)	Temp.Stability (%)	Temperature Range (°C)	Aging (10 years) (%)	Use
CSALS_X	16.00 to 70.00	±0.5	±0.2	-20 to 80	±0.2	For consumer electronics

Irregular or stop oscillation may occur under unmatched circuit conditions. Please check the actual conditions prior to use.
The order quantity should be an integral multiple of the "Minimum Quantity" shown in the packaging page.

■ Oscillation Frequency Measuring Circuit

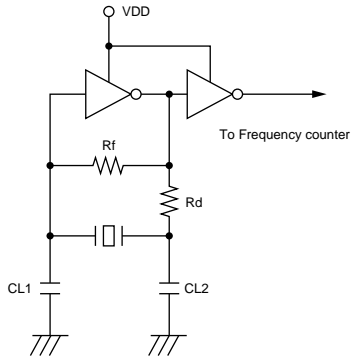

■ Oscillation Frequency Temperature Stability

CSALS_X

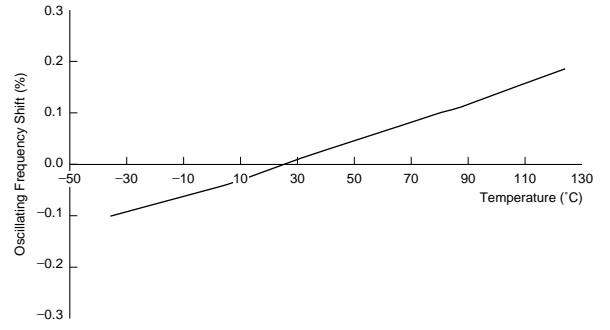

MHz Lead Type Notice

■ Notice (Soldering and Mounting)

The component cannot be withstand washing.

■ Notice (Storage and Operating Conditions)

Please do not apply excess mechanical stress to the component and lead terminals at soldering.

Conformal coating or washing to the component is not acceptable. Because it is not hermetically sealed.

■ Notice (Rating)

The component may be damaged if excess mechanical stress is applied.

■ Notice (Handling)

"CERALOCK" may stop oscillating or oscillate irregularly under improper circuit conditions.

MHz Lead Type CSTLS Series Packaging

■ Minimum Quantity

Part Number	Ammo Pack	Bulk
CSTLS_G (3.40 to 10.0MHz)	2,000	500
CSTLS_X (16.00 to 70.00MHz)	2,000	500

The order quantity should be an integral multiple of the "Minimum Quantity" shown above.

(pcs.)

■ Tape Dimensions of CSTLS_G

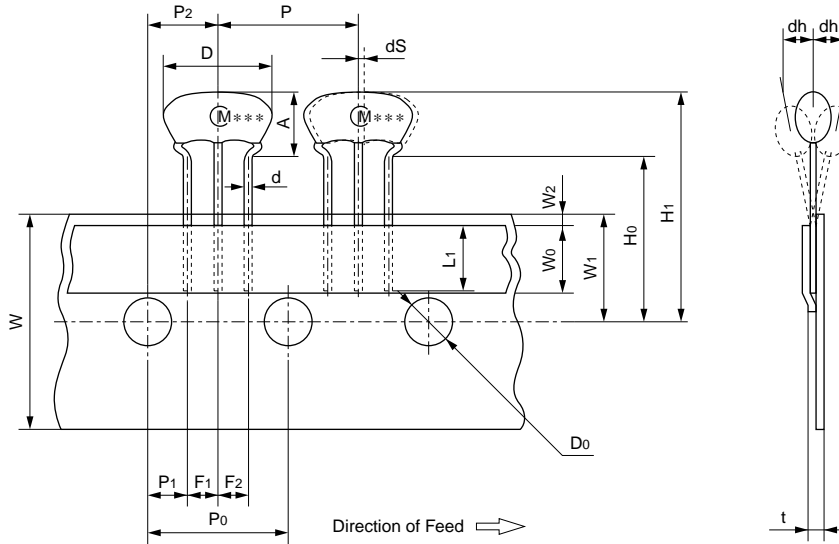

Item	Code	Dimensions	Tolerance	Remarks
Width of diameter	D	8.0	±1.0	
Height of resonator	A	5.5	±0.5	
Dimensions of terminal	d	ø0.48	±0.05	
Lead length under the hold down tape	L ₁	5.0 min.	—	
Pitch of component	P	12.7	±0.5	Tolerance for Pitches 10xP ₀ =127±1
Pitch of sprocket hole	P ₀	12.7	±0.2	
Length from sprocket hole center to lead	P ₁	3.85	±0.5	
Length from sprocket hole center to component center	P ₂	6.35	±0.5	
Lead spacing (I)	F ₁	2.5	±0.2	
Lead spacing (II)	F ₂	2.5	±0.2	
Slant to the forward or backward	dh	0	±1.0	1mm max.
Width of carrier tape	W	18.0	±0.5	
Width of hold down tape	W ₀	6.0 min.	—	Hold down tape does not exceed the carrier tape.
Position of sprocket hole	W ₁	9.0	±0.5	
Gap of hold down tape and carrier tape	W ₂	0	+0.5 -0	
Distance between the center of sprocket hole and lead stopper	H ₀	18.0	±0.5	
Total height of resonator	H ₁	23.5	±1.0	
Diameter of sprocket hole	D ₀	ø4.0	±0.2	
Total tape thickness	t	0.6	±0.2	
Body tilt	dS	0	±1.0	

(in mm)

Continued on the following page.

MHz Lead Type CSTLS Series Packaging

Continued from the preceding page.

■ Tape Dimensions of CSTLS_X

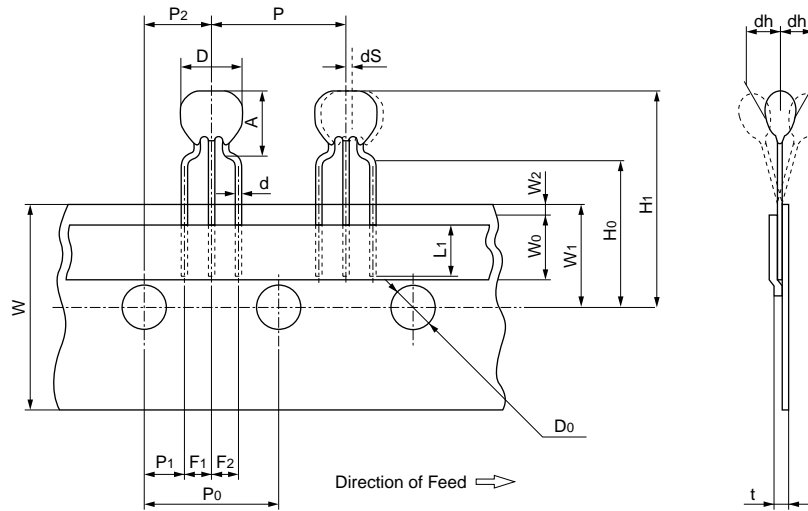

Item	Code	Dimensions	Tolerance	Remarks
Width of diameter	D	5.5	± 1.0	
Height of resonator	A	6.5	± 0.5	
Dimensions of terminal	d	$\phi 0.48$	± 0.05	
Lead length under the hold down tape	L1	5.0 min.	—	
Pitch of component	P	12.7	± 0.5	Tolerance for Pitches $10 \times P_0 = 127 \pm 1$
Pitch of sprocket hole	P0	12.7	± 0.2	
Length from sprocket hole center to lead	P1	3.85	± 0.5	
Length from sprocket hole center to component center	P2	6.35	± 0.5	
Lead spacing (I)	F1	2.5	± 0.2	
Lead spacing (II)	F2	2.5	± 0.2	
Slant to the forward or backward	dh	0	± 1.0	1mm max.
Width of carrier tape	W	18.0	± 0.5	
Width of hold down tape	W0	6.0 min.	—	Hold down tape doesn't exceed the carrier tape.
Position of sprocket hole	W1	9.0	± 0.5	
Gap of hold down tape and carrier tape	W2	0	$+0.5$ -0.0	
Distance between the center of sprocket hole and lead stopper	H0	18.0	± 0.5	
Total height of resonator	H1	24.5	± 0.1	
Diameter of sprocket hole	D0	$\phi 4.0$	± 0.2	
Total tape thickness	t	0.6	± 0.2	
Body tilt	dS	0	± 1.0	

(in mm)

MHz Lead Type CSALS Series Packaging

■ Minimum Quantity

Part Number	Ammo Pack	Bulk
CSALS_X (16.00 to 70.00MHz)	2,000	500

The order quantity should be an integral multiple of the "Minimum Quantity" shown above.

(pcs.)

■ Tape Dimensions of CSALS

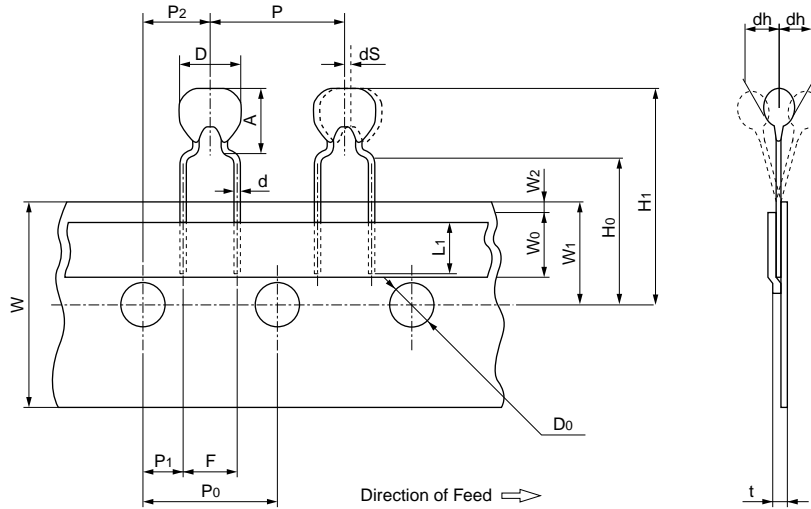

Item	Code	Dimensions	Tolerance	Remarks
Width of diameter	D	5.5	± 1.0	
Height of resonator	A	6.5	± 0.5	
Dimensions of terminal	d	$\phi 0.48$	± 0.05	
Lead length under the hold down tape	L1	5.0 min.	—	
Pitch of component	P	12.7	± 0.5	Tolerance for Pitches $10 \times P_0 = 127 \pm 1$
Pitch of sprocket hole	P0	12.7	± 0.2	
Length from sprocket hole center to lead	P1	3.85	± 0.5	
Length from sprocket hole center to component center	P2	6.35	± 0.5	
Lead spacing	F	5.0	± 0.3	
Slant to the forward or backward	dh	0	± 1.0	1mm max.
Width of carrier tape	W	18.0	± 0.5	
Width of hold down tape	W0	6.0 min.	—	Hold down tape doesn't exceed the carrier tape.
Position of sprocket hole	W1	9.0	± 0.5	
Gap of hold down tape and carrier tape	W2	0	$+0.5$ -0	
Distance between the center of sprocket hole and lead stopper	H0	18.0	± 0.5	
Total height of resonator	H1	24.5	± 1.0	
Diameter of sprocket hole	D0	$\phi 4.0$	± 0.2	
Total tape thickness	t	0.6	± 0.2	
Body tilt	dS	0	± 1.0	

(in mm)

Ceramic Resonators (CERALOCK®)



Chip Type Two-Terminals CSBFB Series

Can be reflow soldered and mounted by automatic placers. MURATA's original package technologies have enabled the development of the kHz band "CERALOCK". The series is perfect in miniature remote control units and AV modules.

■ Features

1. The series withstands reflow soldering.
2. The series is mountable by automatic placers.
3. No adjustment is necessary for oscillation circuits.

■ Applications

- Clock oscillators for microprocessors.
- OA equipment.
- AV modules.



CSBFB_J
430-519kHz

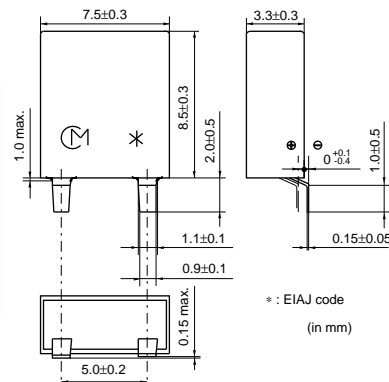

CSBFB_J
700-1250kHz

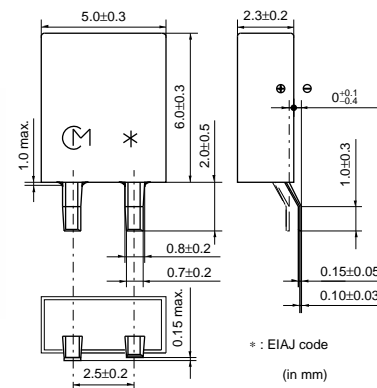

Part Number	Oscillating Frequency (kHz)	Initial Tolerance (%)	Temp.Stability (%)	Temperature Range (°C)	Aging (10 years) (%)	Use
CSBFB_J	430 to 519, 700 to 1250	±0.5	±0.3	-20 to 80	±0.3	-

Irregular or stop oscillation may occur under unmatched circuit conditions. Please check the actual conditions prior to use.

■ Oscillation Frequency Measuring Circuit

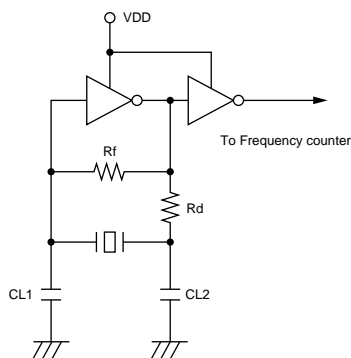

■ Oscillation Frequency Temperature Stability

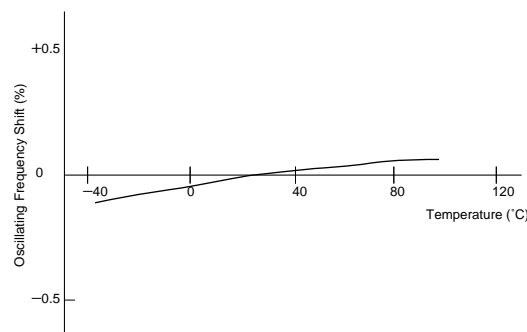

Continued on the following page.

☐ Continued from the preceding page.

■ Standard Land Pattern Dimensions

CSBFB_J (430-519kHz)

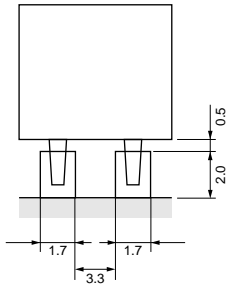

(in mm)

CSBFB_J (700-1250kHz)

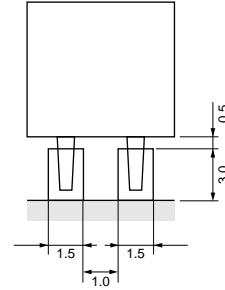

(in mm)

kHz Chip Type CSBFB_J 430-519kHz Notice (Soldering and Mounting)

1. Soldering Condition

(1) Reflow

Right profile of heat stress is applied to resonator, then being place in natural condition for 1 hour, resonator shall be measured.

1. Pre-heating conditions shall be +140 to +160°C for 60 to 120 seconds. Ascending time up to +150°C shall be longer than 30 second.
2. Heating conditions shall be within 20 seconds at +225°C min., but peak temperature shall be lower than +235°C.

(2) Soldering Iron

Soldering iron of +270±5°C shall be placed 0.5mm above from electrode of resonator. Melting solder through soldering iron shall be applied to electrode for 3±1 seconds, then being place in natural condition for 24 hour, resonator shall be measured.

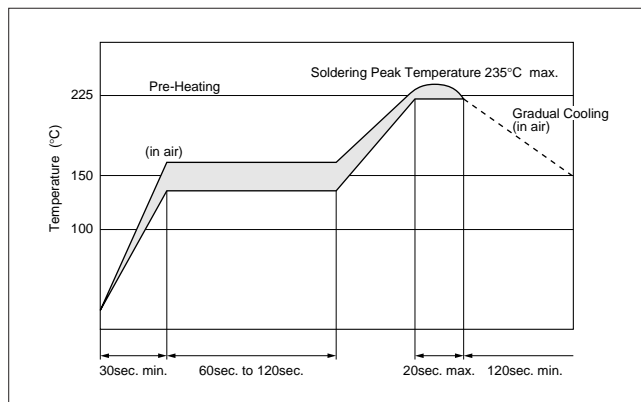

2. Wash

(1) Cleaning Solvent

HCFC, Isopropanol, Tap water, Demineralized water, Cleanthrough750H, Pine alpha 100S, Techno care FRW

(2) Temperature Difference : dT *1

$dT \leq 60^\circ\text{C}$ (dT=Component-solvent)

*1 ex. In case the component at +90°C immerses into cleaning solvent at +60°C, then dT=30°C.

(3) Condition

1. Ultrasonic Wash

1 minute max. in above solvent at +60°C max.
(Frequency : 28kHz, Output : 20W/L)

2. Immersion Wash

5 minutes max. in above solvent at +60°C max.

3. Shower or Rinse Wash

5 minutes max. in above solvent at +60°C max.

(4) Drying

5 minutes max. by air blow at +80°C max.

(5) Others

1. Total washing time should be within 10 minutes.
2. Please insure the component is thoroughly evaluated in your application circuit.
3. The component may be damaged if it is washed with chlorine, petroleum, or alkali cleaning solvent.

kHz Chip Type CSBFB_J 700-1250kHz Notice (Soldering and Mounting)

1. Soldering Condition

(1) Reflow

Right profile of heat stress is applied to resonator, then being place in natural condition for 1 hour, resonator shall be measured.

1. Pre-heating conditions shall be +140 to +160°C for 60 to 120 seconds. Ascending time up to +150°C shall be longer than 30 second.
2. Heating conditions shall be within 20 seconds at +215°C min., but peak temperature shall be lower than +225°C.

(2) Soldering Iron

Soldering iron of +270±5°C shall be placed 0.5mm above from electrode of resonator. Melting solder through soldering iron shall be applied to electrode for 3±1 seconds, then being place in natural condition for 24 hour, resonator shall be measured.

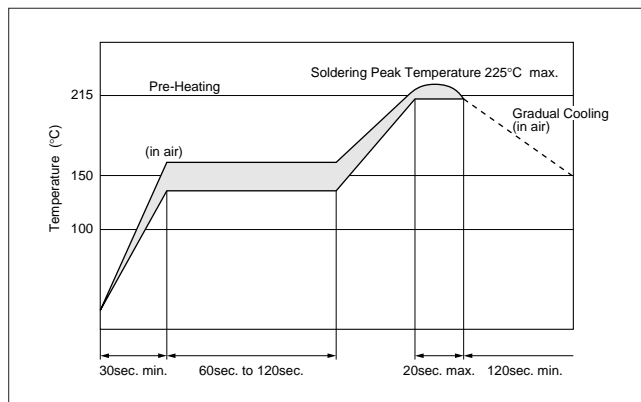

2. Wash

(1) Cleaning Solvent

HCFC, Isopropanol, Tap water, Demineralized water, Cleanthrough750H, Pine alpha 100S, Techno care FRW

(2) Temperature Difference : $dT * 1$

$dT \leq 60^\circ\text{C}$ ($dT = \text{Component} - \text{solvent}$)

*1 ex. In case the component at +90°C immerses into cleaning solvent at +60°C, then $dT = 30^\circ\text{C}$.

(3) Condition

1. Ultrasonic Wash

1 minute max. in above solvent at +60°C max.
(Frequency : 28kHz, Output : 20W/L)

2. Immersion Wash

5 minutes max. in above solvent at +60°C max.

3. Shower or Rinse Wash

5 minutes max. in above solvent at +60°C max.

(4) Drying

5 minutes max. by air blow at +80°C max.

(5) Others

1. Total washing time should be within 10 minutes.
2. Please insure the component is thoroughly evaluated in your application circuit.
3. The component may be damaged if it is washed with chlorine, petroleum, or alkali cleaning solvent.

Ceramic Resonators (CERALOCK®)



Lead Type Two-Terminals CSBLA Series

"CERALOCK" with two leaded terminals.

The CSBLA series ceramic resonator owe their development to MURATA's innovative expert technologies and the application of mass production techniques typically utilized in the manufacture of piezoelectric ceramic components. Because of their high mechanical Q and consistent high quality, the CSBLA series are ideally suited to microprocessor and remote control unit applications.

■ Features

1. The series is stable over a wide temperature range and with respect to long-term aging.
2. The series comprises fixed, tuned, solid-state devices.
3. The resonators are miniature and light weight.
4. They exhibit excellent shock resistance performance.
5. Oscillating circuits requiring no adjustment can be designed by utilizing these resonators in conjunction with transistors or appropriate ICs.

■ Applications

- Square-wave and sine-wave oscillator.
- Clock generator for microprocessors.
- Remote control systems.



CSBLA_E
375-429kHz

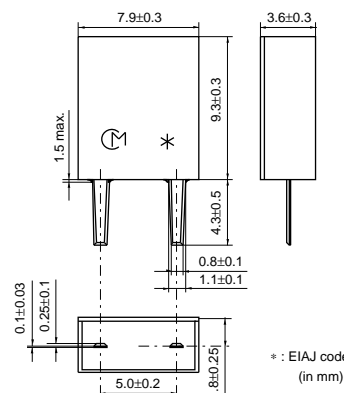

CSBLA_E
430-509kHz

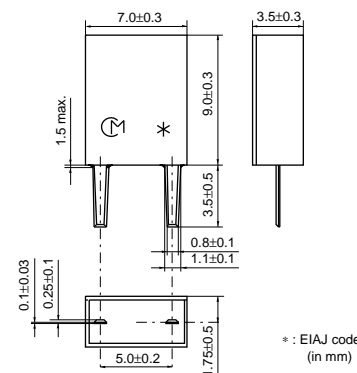

CSBLA_E
510-699kHz

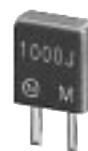
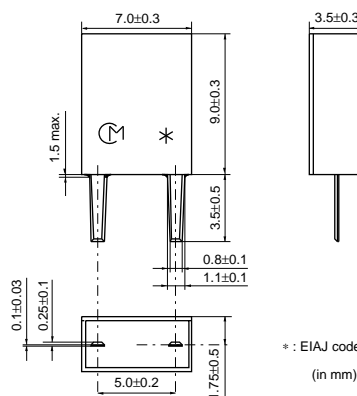

CSBLA_J
700-1250kHz

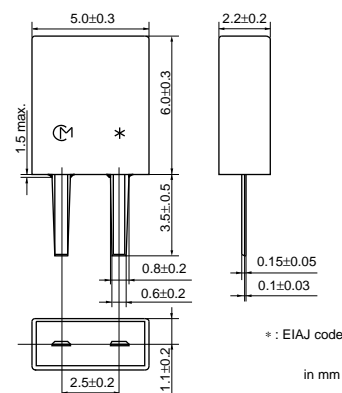

Part Number	Oscillating Frequency (kHz)	Initial Tolerance	Temp.Stability (%)	Temperature Range (°C)	Aging (10 years) (%)	Use
CSBLA_E	375 to 699	±2kHz	±0.3	-20 to 80	±0.3	-
CSBLA_J	700 to 1250	±0.5%	±0.3	-20 to 80	±0.3	-

Irregular or stop oscillation may occur under unmatched circuit conditions. Please check the actual conditions prior to use.
 The order quantity should be an integral multiple of the "Minimum Quantity" shown in the packaging page.

■ Oscillation Frequency Measuring Circuit

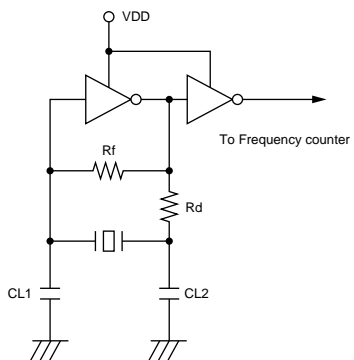

■ Oscillation Frequency Temperature Stability

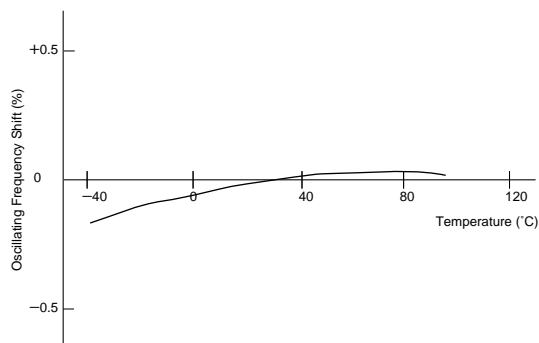

kHz Lead Type Notice

■ Notice (Soldering and Mounting)

CSBLA_E

The component cannot be withstand washing.

■ Notice (Soldering and Mounting)

CSBLA_J

(1) Cleaning Solvent

HCFC, Isopropanol, Tap water, Demineralized water,
Cleanthrough750H, Pine alpha 100S, Techno care
FRW.

(2) Temperature Difference:dT *1

$dT \leq 30$ C. (dT=Component-solvent)

*1 ex. In case the component at +90 C. immerses
into cleaning solvent at +60 C., then
 $dT=30$ C.

(3) Condition

1. Ultrasonic Wash

1 minute max. in above solvent at +60 C. max.
(Frequency:28kHz, Output:20W/L)

2. Immersion Wash

5 minutes max. in above solvent at +60 C. max.

3. Shower or Rinse Wash

5 minutes max. in above solvent at +60 C. max.

(4) Drying

5 minutes max. by air blow at +80 C. max.

(5) Others

1. Total washing time should be within 10 minutes.

2. Please insure the component is thoroughly
evaluated in your application circuit.

3. The component may be damaged if it is washed
with alkali cleaning solvent.

kHz Type Notice

■ Notice (Storage and Operating Condition)

CSBFB_J

Please do not apply excess mechanical stress to the component and lead terminals at soldering.

Conformal coating of the component is acceptable.

However, the resin material, curing temperature, and other process conditions should be evaluated to confirm stable electrical characteristics are maintained.

Ultrasonic cleaning of the component is acceptable.

However, the size of bath, size and thickness of PBC should be evaluated to confirm stable electrical characteristics are maintained.

In case of the bulk component, dry heating treatment (130 C. for 5 hours min.) is required before reflow soldering. Then, the component should be soldering within 48 hours after dry heating treatment.

■ Notice (Storage and Operating Condition)

CSBLA_E

Please do not apply excess mechanical stress to the component and lead terminals at soldering.

Conformal coating or washing to the component is not acceptable. Because it is not hermetically sealed.

■ Notice (Storage and Operating Condition)

CSBLA_J

Please do not apply excess mechanical stress to the component and lead terminals at soldering.

Conformal coating of the component is acceptable.

However, the resin material, curing temperature, and other process conditions should be evaluated to confirm stable electrical characteristics are maintained.

Ultrasonic cleaning of the component is acceptable.

However, the size of bath, size and thickness of PBC should be evaluated to confirm stable electrical characteristics are maintained.

■ Notice (Rating)

The component may be damaged if excess mechanical stress is applied.

■ Notice (Handling)

"CERALOCK" may stop oscillating or oscillate irregularly under improper circuit conditions.

kHz Type Packaging

■ CSBFB Series Minimum Quantity

Part Number	Plastic Tape ø330mm	Bulk
CSBFB_J (430 to 519kHz)	1,500	500
CSBFB_J (700 to 1250kHz)	3,000	1,000

The order quantity should be an integral multiple of the "Minimum Quantity" shown above.

(pcs.)

■ Dimensions of Reel

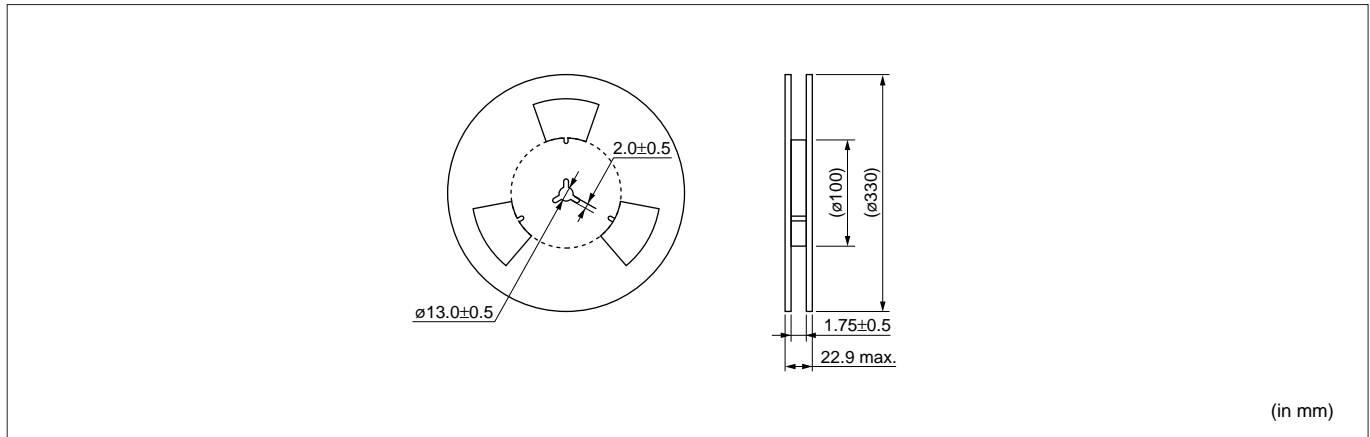

(in mm)

■ Dimensions of Taping

CSBFB_J 430-519kHz

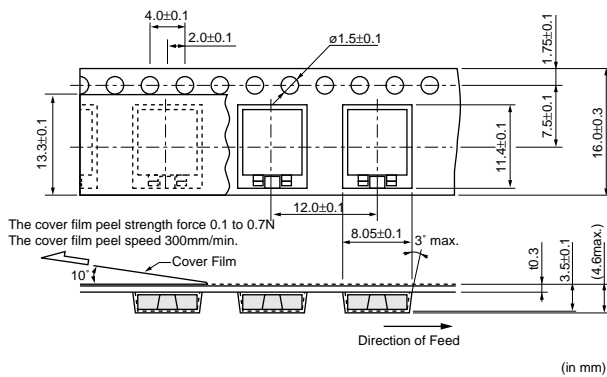

(in mm)

CSBFB_J 700-1250kHz

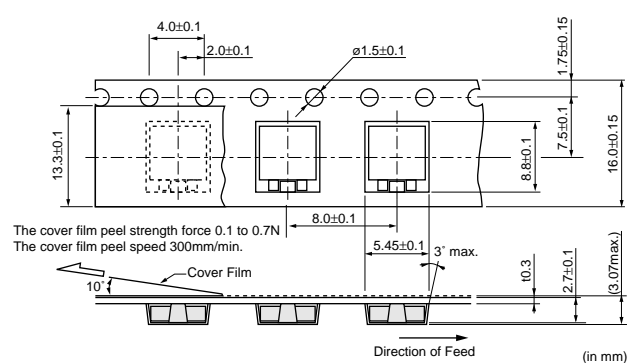

(in mm)

■ CSBLA Series Minimum Quantity

Part Number	Magazine	Bulk
CSBLA_E	50	500
CSBLA_J	100	1,000

The order quantity should be an integral multiple of the "Minimum Quantity" shown above.

(pcs.)

Application Circuits Utilizing

■ TMP87CM40AN (TOSHIBA)

8-bit Microcomputer

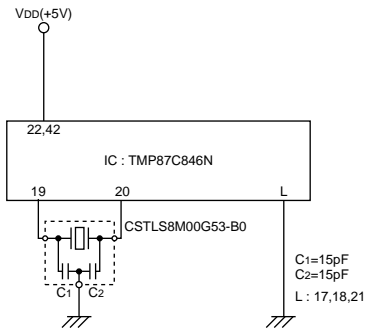

■ MC68HC908JB8 (MOTOROLA)

8-bit Microcomputer

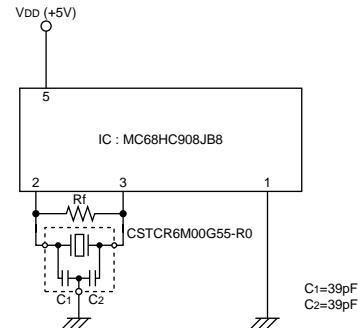

■ uPD78018F (NEC)

8-bit Microcomputer

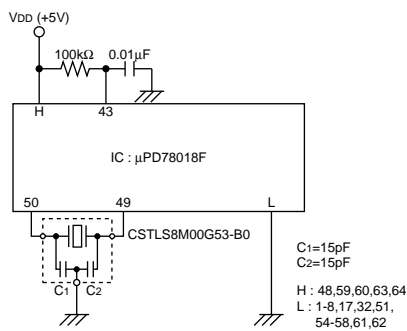

■ HD64F3337 (HITACHI)

8-bit Microcomputer

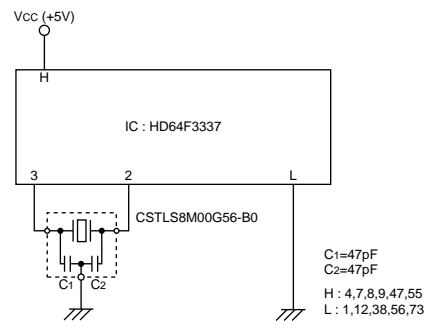

■ ML66517 (OKI)

8-bit Microcomputer

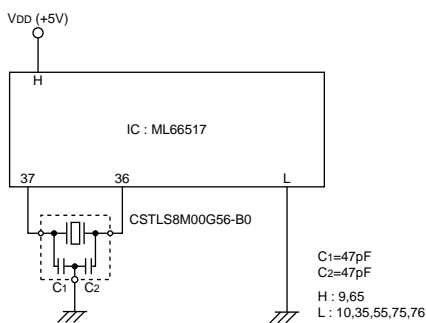

■ M38039MF (MITSUBISHI)

8-bit Microcomputer

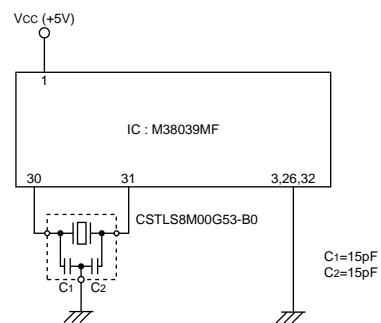

Continued on the following page.

Application Circuits Utilizing

Continued from the preceding page.

■ M34280M1 (MITSUBISHI)

Remote Control Unit

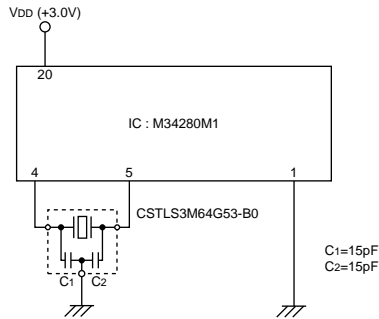

■ uPD65 (NEC)

Speech Synthesizer

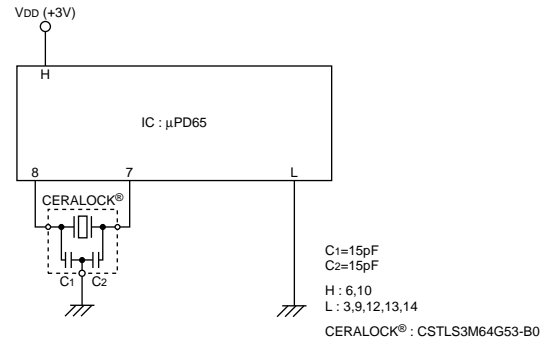

■ uPD754304 (NEC)

4-bit Microcomputer

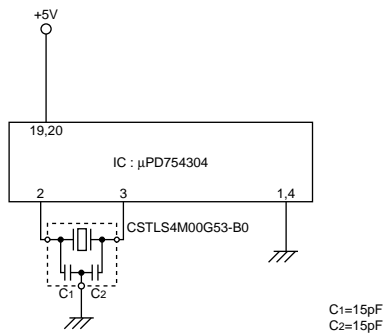

■ LC651154F (SANYO)

4-bit Microcomputer

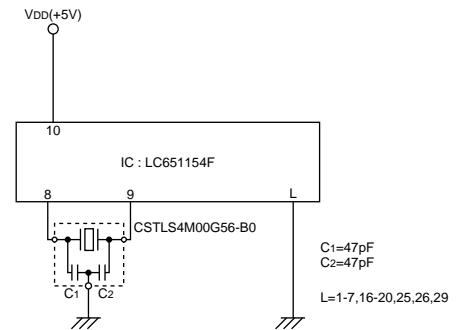

■ LC7367JM (SANYO)

Tone/Pulse Dialer

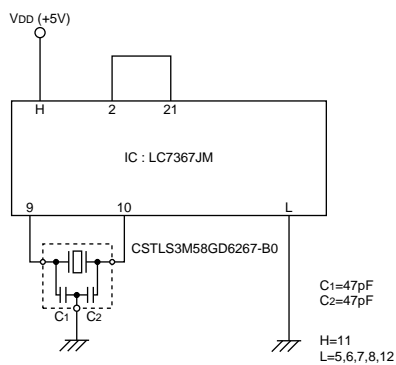

■ ML7005MB (OKI)

Tone/Pulse Dialer

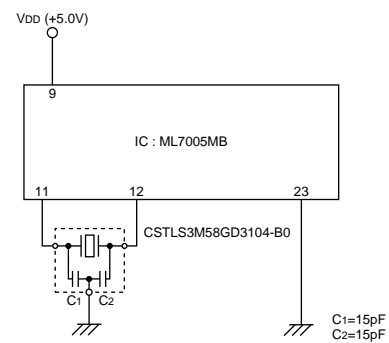

Continued on the following page. ↗

Application Circuits Utilizing

Continued from the preceding page.

■ uPD70F3102GJ (NEC)

32-bit Microcomputer

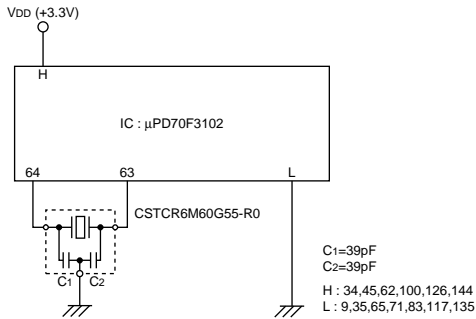

■ CXD3068Q (SONY)

Digital Signal Processing IC for CD

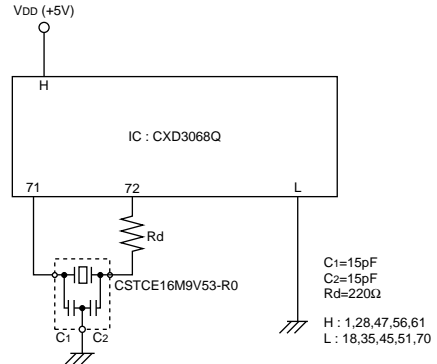

■ LC895299 (SANYO)

Error Correction of CD-ROM LSI

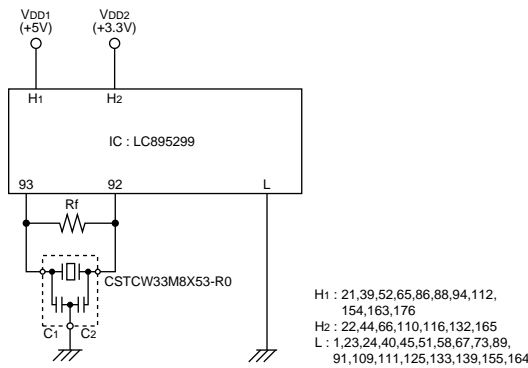

■ TMP47C660AN (TOSHIBA)

4-bit Microcomputer

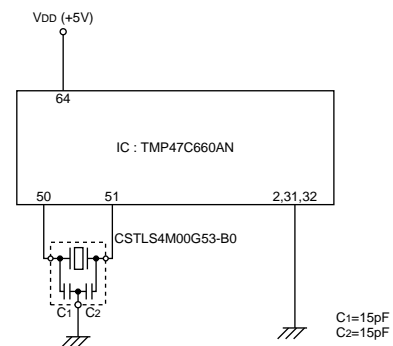

■ TA8690AN (TOSHIBA)

TV Horizontal/Compatible with Synthesizer Circuit

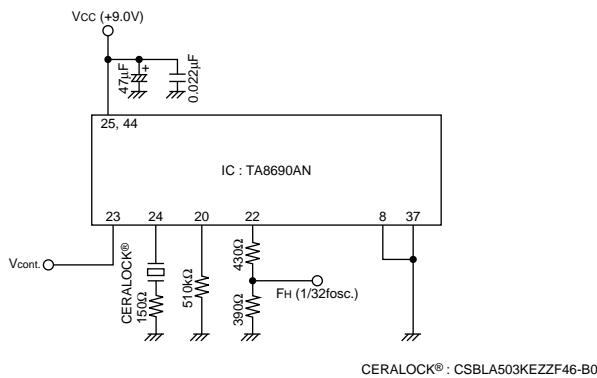

■ LA3410 (SANYO)

FM Stereo MPX

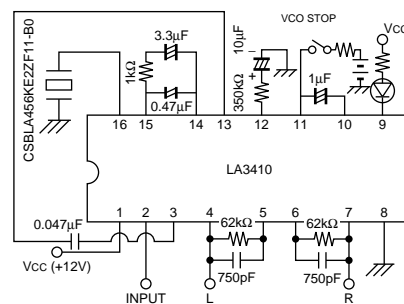

Continued on the following page. ↗

Application Circuits Utilizing

Continued from the preceding page.

■ TEA2130 (THOMSON)

TV Horizontal/Compatible with Synthesizer Circuit

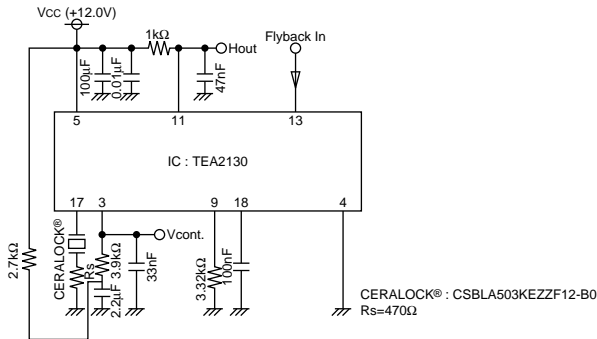

■ LA7687 (SANYO)

TV Horizontal/Compatible with Synthesizer Circuit

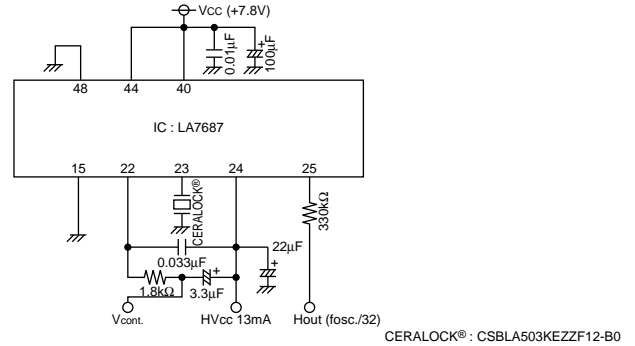

■ Oscillation Circuit Incorporating Transistor

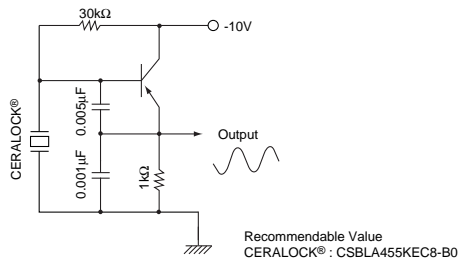

⚠Note:

1. Export Control

⟨For customers outside Japan⟩

Murata products should not be used or sold for use in the development, production, stockpiling or utilization of any conventional weapons or mass-destructive weapons (nuclear weapons, chemical or biological weapons, or missiles), or any other weapons.

⟨For customers in Japan⟩

For products which are controlled items subject to the "Foreign Exchange and Foreign Trade Law" of Japan, the export license specified by the law is required for export.

2. Please contact our sales representatives or product engineers before using our products listed in this catalog for the applications listed below which require especially high reliability for the prevention of defects which might directly cause damage to the third party's life, body or property, or when intending to use one of our products for other applications than specified in this catalog.

- | | |
|-----------------------------|---|
| ① Aircraft equipment | ② Aerospace equipment |
| ③ Undersea equipment | ④ Power plant equipment |
| ⑤ Medical equipment | ⑥ Transportation equipment (vehicles, trains, ships, etc.) |
| ⑦ Traffic signal equipment | ⑧ Disaster prevention / crime prevention equipment |
| ⑨ Data-processing equipment | ⑩ Application of similar complexity and/or reliability requirements to the applications listed in the above |

3. Product specifications in this catalog are as of May 2002. They are subject to change or our products in it may be discontinued without advance notice. Please check with our sales representatives or product engineers before ordering. If there are any questions, please contact our sales representatives or product engineers.

4. Please read rating and ⚠CAUTION (for storage and operating, rating, soldering and mounting, handling) in this catalog to prevent smoking and/or burning, etc.

5. This catalog has only typical specifications because there is no space for detailed specifications. Therefore, please approve our product specification or transact the approval sheet for product specification before ordering.

6. Please read CAUTION and Notice in this catalog for safety. This catalog has only typical specifications. Therefore you are requested to approve our product specification or to transact the approval sheet for product specification, before ordering.

7. Please note that unless otherwise specified, we shall assume no responsibility whatsoever for any conflict or dispute that may occur in connection with the effect of our and/or third party's intellectual property rights and other related rights in consideration of your using our products and/or information described or contained in our catalogs. In this connection, no representation shall be made to the effect that any third parties are authorized to use the rights mentioned above under licenses without our consent.

8. No ozone depleting substances (ODS) under the Montreal Protocol are used in our manufacturing process.