

TPC Film Chip Capacitors

Characteristics of Film SMD Capacitors 2

General Information..... 3

Dimensions..... 4

How To Order..... 4

Capacitance Values and Nominal Voltages 5

Packaging 6-7

Mounting and Soldering Recommendations..... 8

Electrical Properties and Test Conditions 9

Electrical and Frequency Characteristics..... 10

Voltage and Frequency Characteristics..... 11-12

TOTAL QUALITY POLICY

Customer and employees satisfaction is linked to the successful implementation of our QUALITY STRATEGY. This strategy applies AVX's Quality Systems (QV 2000 and QOS) and certification according to ISO9001 and QS9000 standards. These systems are designed as a real management tool, the major elements of which are:

- Main operational and productive processes under control
- Continuous improvement process
- Supplier/partner involvement

TPC with AVX sales and marketing support, wants to be a preferred ranked supplier for product and service quality.

NOTICE: Specifications are subject to change without notice. Contact your nearest AVX Sales Office for the latest specifications. All statements, information and data given herein are believed to be accurate and reliable, but are presented without guarantee, warranty, or responsibility of any kind, expressed or implied. Statements or suggestions concerning possible use of our products are made without representation or warranty that any such use is free of patent infringement and are not recommendations to infringe any patent. The user should not assume that all safety measures are indicated or that other measures may not be required. Specifications are typical and may not apply to all applications.

Film Chip Capacitors



Characteristics of Film SMD Capacitors

	PET-HT (MKT)	PEN (MKN)	PPS (MKI)	NPO	X7R	Tantalum
Operating temperature (°C)	-55/125	-55/125	-55/140	-55/125	-55/125	-55/125
$\Delta C/C$ with temperature (%)	±5	±5	±1.5	±1	±15	±10
DC voltage coefficient (%)	no.	no.	no.	no.	-20	no.
ΔC aging rate (%/h dec.)	negl.	negl.	negl.	negl.	2	n.a.
Dissipation factor (%) 1 kHz 10 kHz 100 kHz	0.8 1.5 3.0	0.8 1.5 3.0	0.2 0.25 0.5	0.10 0.10 0.10	2.5	8
ESR	low	low	very low	low	moderate to high	high
IR (M Ω . μ F) 25°C 85°C	10000 1000	10000 1000	10000 1000	10000 1000	1000 500	100 10
Dielectric absorption (%)	0.5	1	0.05	0.6	2.5	n.a.
Capacitance range from (pF) to (μ F)	1000 10	1000 4.7	100 1	10 0.047	100 4.7	100000 1000
Capacitance tolerance (±%)	15 10 20	5 10 20	2.5 5 10 20	5 10	10 20	10 20
Self-healing	yes	yes	no	no	no	no
Typical failure mode	open	open	open	short	short	short
Reliability	high	high	high	high	moderate	low
Piezoelectric effect	no	no	no	yes	yes	yes
Resistance to thermal and mechanical shock	high	high	high	moderate to low	moderate to low	high
Non-linear distortion (3 rd harmonic)	very low	very low	very low	low	high	n.a.
Polarity	no	no	no	no	no	yes

1) All data are typical values

N.B.: SMD = Surface Mounted Device
SMT = Surface Mounted Technology

Film Chip Capacitors

General Information

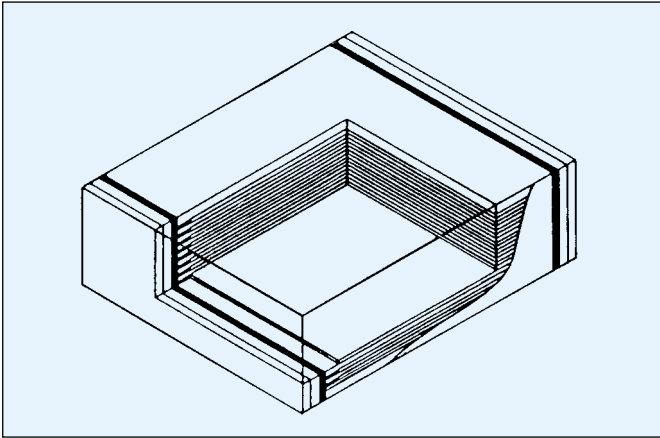

DESCRIPTION

Film chip capacitor using a naked and stacked construction with metallized High Temperature PET (polyethylene terephthalate).

ADVANTAGES

- Use of high temperature dielectric films makes these capacitors suitable for IR or vapor phase reflow processes. This chip is built without specific encapsulation.
- The intrinsic elasticity of the dielectric film allows an excellent compatibility of the capacitor with all types of material for printed circuit boards.
- The self-healing property of film technology results in safe open circuit failure mode and better overall reliability.
- Excellent thermal shock resistance.
- Low dissipation factor, ESR and ESL.
- No piezoelectric effect.
- Available in tape and reel suitable for automatic placement.
- Non-polar construction.

APPLICATIONS

General purpose function in low voltage applications where miniaturization and SMD is required. Typical applications would be:

- Automotive (Airbag, Fuel injection calculator, ...).
- Telecom (Public switching systems, modems, telephone sets, cordless, mobile).
- Industrial (SMPS, Power converter modules, ...).

GENERAL CHARACTERISTICS

Climatic category	55/125/56
Capacitance range	1 nF to 4.7 μ F
Tolerance on capacitance	\pm 5%, \pm 10%
Nominal voltage	25 VDC to 250 VDC
Test voltage	1.4 Vr 2s @ 25°C
Soldering methods	IR or vapor phase reflow (not suitable for wave soldering)
Tangent of loss angle at 1KHz (DF)	$< 100 \times 10^{-4}$
Insulation resistance minimum	for C \leq 0.33 μ F; IR $>$ 1000 M Ω at 20°C for 1 min. charge at 10 VDC for Vr $<$ 100 VDC and 100 VDC for Vr \geq 100 VDC for C $>$ 0.33 μ F; IR \cdot C $>$ 400 sec. at 20°C for 1 min. charge at 10 VDC for Vr $<$ 100 VDC and 100 VDC for Vr \geq 100 VDC
Temperature range	-55°C to +125°C with voltage derating of 1.25%/°C between 105°C and 125°C

DIMENSIONS

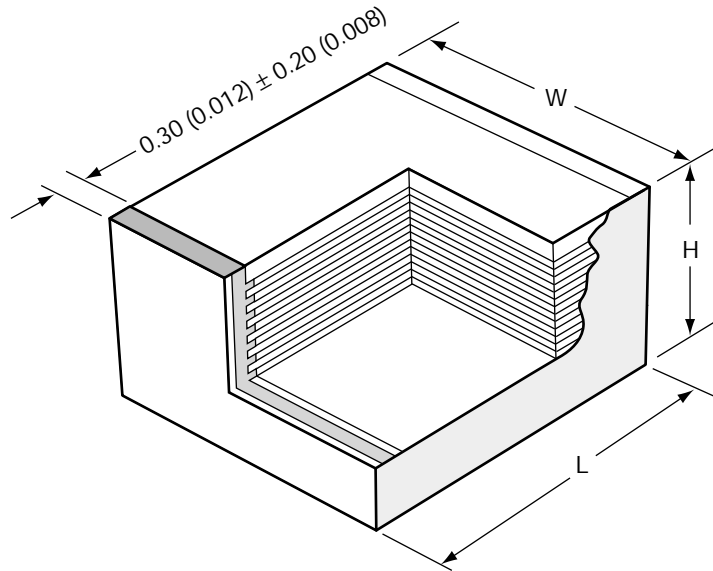

millimeters (inches)

Size Code	01-21	02-22	03-23	04-24	05-25	16-26	17-27	18-28
Equivalent Size	1206	1210	1812	2220	2824	4030	5040	6054
Length (L) mm (inches)	3.20 ± 0.30 (0.126 ± 0.012)	3.20 ± 0.30 (0.126 ± 0.012)	4.50 ± 0.50 (0.177 ± 0.020)	5.70 ± 0.50 (0.224 ± 0.020)	7.10 ± 0.50 (0.280 ± 0.020)	10.2 ± 0.60 (0.401 ± 0.024)	12.7 ± 0.60 (0.500 ± 0.024)	15.2 ± 0.60 (0.598 ± 0.024)
Width (W) mm (inches)	1.60 ± 0.30 (0.063 ± 0.012)	2.50 ± 0.30 (0.098 ± 0.012)	3.20 ± 0.50 (0.126 ± 0.020)	5.00 ± 0.50 (0.197 ± 0.020)	6.10 ± 0.50 (0.240 ± 0.020)	7.60 ± 0.80 (0.299 ± 0.031)	10.2 ± 0.80 (0.401 ± 0.031)	13.7 ± 0.80 (0.539 ± 0.031)

HOW TO ORDER

CF

Type

04

Size

01 or 21 = 1206
02 or 22 = 1210
03 or 23 = 1812
04 or 24 = 2220
05 or 25 = 2824
16 or 26 = 4030
17 or 27 = 5040
18 or 28 = 6054

2

Dielectric
2 = PET- HT

G

Voltage
25 V = C
50/63 V = D
100 V = E
160 V = F
250 V = G

0105

Capacitance
EIA Code

* 1st digit: 0 (zero).
* 2nd & 3rd: the 2nd significant figures of the capacitance value.
* 4th digit: the number of zeros to be added to the capacitance value.

K

Tolerance
5% = J
10% = K

--

Suffix
-- = Bulk
BA = Tape & reel
Ø 180mm (7")
BC = Tape & reel
Ø 330mm (13")

Standard range
Extended range

Film Chip Capacitors

Capacitance and Voltage Range



CAPACITANCE VALUES AND NOMINAL VOLTAGES vs SIZE

millimeters (inches)

Capacitance		Voltages (Vdc/Vac)													
		25 Vdc/16Vac		50 Vdc/40Vac		63 Vdc/40Vac		100 Vdc/63Vac		160 Vdc/100Vac		250 Vdc/160Vac			
Cap Code	Size Code	H max	Size Code	H max	Size Code	H max	Size Code	H max	Size Code	H max	Size Code	H max	Size Code	H max	
1 nF	0102	1206	1.10	1206	1.10	1812	1.50	1812/1206	1.50/1.10	1812	1.50	1812	1.50	1812	1.50
1.5	0152	1206	1.10	1206	1.10	1812	1.50	1812/1206	1.50/1.10	1812	1.50	1812	1.50	1812	1.50
2.2	0222	1206	1.10	1206	1.10	1812	1.50	1812/1206	1.50/1.10	1812	1.50	1812	1.50	1812	1.50
3.3	0332	1206	1.10	1206	1.10	1812	1.50	1812/1206	1.50/1.10	1812	1.50	1812	1.50	1812	1.50
4.7	0472	1206	1.10	1206	1.10	1812	1.50	1812/1206	1.50/1.30	1812	1.50	1812	1.50	1812	1.50
6.8	0682	1206	1.10	1206	1.10	1812	1.50	1812/1210/1206	1.50/1.60/1.10	1812	1.50	1812	1.50	1812	1.50
10	0103	1206	1.30	1206	1.30	1812	1.50	1812/1210/1206	1.50/1.60/1.30	1812	1.50	1812	1.50	1812	1.50
15	0153	1206	1.30	1210/1206	1.80/1.30	1812	1.50	1812/1210/1206	1.50/1.80/1.30	1812	1.50	1812	1.50	1812	2.50
22	0223	1206	1.30	1210/1206	2.20/1.30	1812	1.50	1812/1210/1206	1.50/2.20/1.30	1812	2.00	2220/1812	2.00/1.70	2220/1812	2.00/1.70
33	0333	1210/1206	2.20/1.30	1210/1206	2.20/1.30	1812	1.50	1812/1210	1.50/2.00	1812	2.50	2220/1812	2.00/2.50	2220/1812	2.00/2.50
47	0473	1210	1.80	1210	1.80	1812	2.00	1812/1210	2.00/2.20	2220	2.10	2220/2220	3.00/2.40	2220/2220	3.00/2.40
68	0683	1210	2.20	1210	2.20	1812	2.00	1812/1210	3.00/2.30	2220	3.00	2220/2220	4.00/2.40	2220/2220	4.00/2.40
100	0104	1210	2.20	1210	2.20	1812	2.00	1812/1812	3.00/1.80	2220	3.40	2824/2220	3.60/3.50	2824/2220	3.60/3.50
150	0154					1812/1812	2.50/2.10	2220/1812	3.00/2.60	2824	5.10	2824/2220	5.10/4.20	2824/2220	5.10/4.20
220	0224					1812/1812	3.00/2.60	2220/2220	4.50/2.00	2824	5.00	4030/2824	3.80/4.60	4030/2824	3.80/4.60
330	0334					2220/2220	3.40/2.30	2220/2220	4.50/2.80	4030	3.80	4030/4030	5.80/4.00	4030/4030	5.80/4.00
470	0474					2220/2220	4.00/2.70	2824/2220	3.50/3.90	5040	3.80	5040/4030	4.60/5.50	5040/4030	4.60/5.50
680	0684					2220/2220	4.50/4.10	2824/2824	5.10/3.50	5040	4.60	6054/5040	4.40/4.60	6054/5040	4.40/4.60
1µF	0105					2824/2220	5.00/4.40	4030/2824	4.80/5.10	6054	4.40	6054/5040	5.70/6.60	6054/5040	5.70/6.60
1.5	0155					5040/2824	4.60/4.80	5040/4030	4.60/4.30	6024	6.20	6054	5.90	6054	5.90
2.2	0225					5040/2824	5.50/5.60	5040/4030	5.50/6.00						
3.3	0335					6054/4030	5.70/5.80	6054/5040	5.70/5.40						
4.7	0475					6054/5040	6.00/5.70	6054/6054	7.00/4.80						

*For size code vs case code see "How to Order" page 4.

Standard range
 Extended range
 Development range

MILLIMETERS/INCHES CORRESPONDENCE

millimeters (inches)

1.10 (0.043)	1.30 (0.051)	1.50 (0.059)	1.60 (0.063)	1.70 (0.067)	1.80 (0.071)	2.00 (0.079)	2.10 (0.083)	2.20 (0.087)	2.30 (0.091)	2.40 (0.094)	2.50 (0.098)	2.60 (0.103)	2.70 (0.110)	2.80 (0.110)	3.00 (0.118)	3.40 (0.134)	3.50 (0.137)	3.60 (0.142)	3.80 (0.150)
3.90 (0.154)	4.00 (0.157)	4.10 (0.162)	4.20 (0.166)	4.30 (0.170)	4.40 (0.170)	4.50 (0.178)	4.60 (0.181)	4.80 (0.189)	5.00 (0.195)	5.10 (0.201)	5.40 (0.213)	5.50 (0.217)	5.60 (0.221)	5.70 (0.224)	5.80 (0.227)	5.90 (0.230)	6.00 (0.234)	6.60 (0.258)	7.00 (0.274)

TAPE AND REEL DIMENSIONS

The CF Series is available in bulk or tape and reel for automatic insertion.

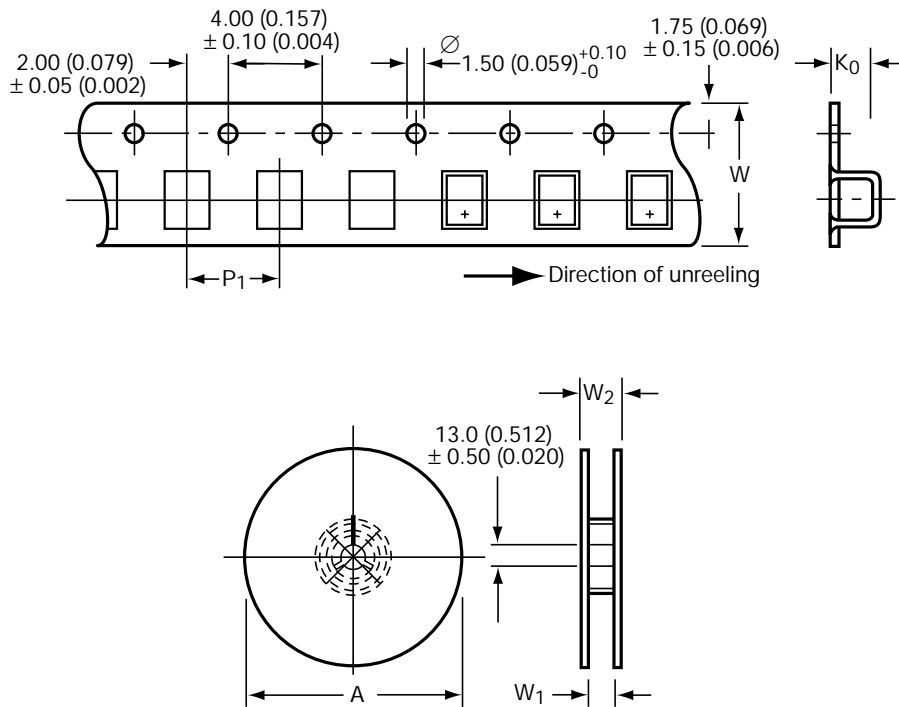

TAPE AND REEL CHARACTERISTICS

In accordance with IEC 286 and EIA 481, the material used:

- Carrier tape: Antistatic Material
- Cover tape: Polyester
- Reel: Recyclable Material

Parts in bulk or on reel are packed in hermetically sealed plastic bags.

RECOMMENDATIONS

Once the bag is open, the capacitors must be kept in a dry atmosphere: $25^{\circ}\pm 5^{\circ}\text{C}$ and R.H. $\leq 60\%$ until soldering and during maximum 3 months.

The use-by date is 3 years if kept in origin plastic bags.

In case of bad storage the following recommendations must be applied: in order to eliminate the humidity level in the CF product after storage out of the vacuum bag, the drying of the pieces can be realized during 48 hours at 80°C .

Film Chip Capacitors



Packaging

Tape and Reel Characteristics and Packaging Quantities

millimeters (inches)

Size Code	Chip Dimensions			Tape Dimensions			Reel Dimensions			Bulk Qty/ bag	Tape Qty/ reel	Packaging Code
	L	W	H max	W	P1	Ko	A	W1	W2 max			
1206	3.20 (0.126)	1.60 (0.063)	1.10 (0.043)	8.00 (0.315)	4.00 (0.157)	1.20 (0.047)	180 (7.090)	8.40 (0.331)	14.4 (0.567)	2000	3900	BA
			1.30 (0.051)	8.00 (0.315)	4.00 (0.157)	1.40 (0.055)	180 (7.090)	8.40 (0.331)	14.4 (0.567)		3400	BA
1210	3.20 (0.126)	2.50 (0.098)	1.80 (0.071)	8.00 (0.315)	4.00 (0.157)	1.90 (0.075)	180 (7.090)	8.40 (0.331)	14.4 (0.567)	2000	2500	BA
			2.30 (0.091)	8.00 (0.315)	4.00 (0.157)	2.33 (0.092)	180 (7.090)	8.40 (0.331)	14.4 (0.567)		2000	BA
1812	4.50 (0.178)	3.20 (0.126)	1.50 (0.059)	12.0 (0.472)	8.00 (0.315)	1.60 (0.063)	180 (7.090)	12.4 (0.488)	18.4 (0.724)	1500	1500	BA
			2.00 (0.079)	12.0 (0.472)	8.00 (0.315)	2.06 (0.081)	180 (7.090)	12.4 (0.488)	18.4 (0.724)		1200	BA
			2.50 (0.098)	12.0 (0.472)	8.00 (0.315)	2.60 (0.103)	180 (7.090)	12.4 (0.488)	18.4 (0.724)		900	BA
			3.00 (0.118)	12.0 (0.472)	8.00 (0.315)	3.10 (0.122)	180 (7.090)	12.4 (0.488)	18.4 (0.724)		700	BA
			1.50 (0.059)	12.0 (0.472)	8.00 (0.315)	1.60 (0.063)	330 (12.99)	12.4 (0.488)	18.4 (0.724)	1500	5800	BC
			2.00 (0.079)	12.0 (0.472)	8.00 (0.315)	2.06 (0.081)	330 (12.99)	12.4 (0.488)	18.4 (0.724)		4500	BC
			2.50 (0.098)	12.0 (0.472)	8.00 (0.315)	2.60 (0.103)	330 (12.99)	12.4 (0.488)	18.4 (0.724)		3600	BC
			3.00 (0.118)	12.0 (0.472)	8.00 (0.315)	3.10 (0.122)	330 (12.99)	12.4 (0.488)	18.4 (0.724)		3000	BC
2220	5.70 (0.224)	5.00 (0.195)	2.00 (0.079)	12.0 (0.472)	8.00 (0.315)	2.10 (0.083)	330 (12.99)	12.4 (0.488)	18.4 (0.724)	1500	4400	BC
			2.10 (0.083)	12.0 (0.472)	8.00 (0.315)	2.18 (0.086)	330 (12.99)	12.4 (0.488)	18.4 (0.724)		4300	BC
			2.80 (0.110)	12.0 (0.472)	8.00 (0.315)	3.10 (0.122)	330 (12.99)	12.4 (0.488)	18.4 (0.724)		3000	BC
			3.00 (0.118)	12.0 (0.472)	8.00 (0.315)	3.45 (0.136)	330 (12.99)	12.4 (0.488)	18.4 (0.724)		2800	BC
			4.00 (0.157)	12.0 (0.472)	8.00 (0.315)	4.10 (0.162)	330 (12.99)	12.4 (0.488)	18.4 (0.724)		2300	BC
			4.50 (0.178)	16.0 (0.630)	8.00 (0.315)	4.60 (0.181)	330 (12.99)	16.4 (0.646)	22.4 (0.882)		1900	BC
2824	7.10 (0.280)	6.10 (0.240)	3.60 (0.142)	24.0 (0.945)	12.0 (0.472)	3.73 (0.147)	330 (12.99)	24.4 (0.961)	30.4 (1.197)	1000	1600	BC
			5.00 (0.195)	16.0 (0.630)	12.0 (0.472)	5.23 (0.206)	330 (12.99)	16.4 (0.646)	22.4 (0.882)		1100	BC
			5.10 (0.201)	16.0 (0.630)	12.0 (0.472)	5.50 (0.217)	330 (12.99)	16.4 (0.646)	22.4 (0.882)		1000	BC
			5.60 (0.221)	16.0 (0.630)	12.0 (0.472)	5.90 (0.230)	330 (12.99)	16.4 (0.646)	22.4 (0.882)		900	BC
4030	10.2 (0.402)	7.60 (0.299)	3.80 (0.150)	24.0 (0.945)	12.0 (0.472)	3.93 (0.155)	330 (12.99)	24.4 (0.961)	30.4 (1.197)	500	1400	BC
			4.80 (0.189)	16.0 (0.630)	12.0 (0.472)	4.90 (0.193)	330 (12.99)	16.4 (0.646)	22.4 (0.882)		1100	BC
			6.00 (0.234)	24.0 (0.945)	12.0 (0.472)	6.19 (0.244)	330 (12.99)	24.4 (0.961)	30.4 (1.197)		900	BC
5040	12.7 (0.500)	10.2 (0.402)	3.80 (0.150)	24.0 (0.945)	16.0 (0.630)	4.00 (0.157)	330 (12.99)	24.4 (0.961)	30.4 (1.197)	300	1100	BC
			4.60 (0.181)	24.0 (0.945)	16.0 (0.630)	4.70 (0.185)	330 (12.99)	24.4 (0.961)	30.4 (1.197)		900	BC
			5.50 (0.217)	24.0 (0.945)	16.0 (0.630)	5.70 (0.224)	330 (12.99)	24.4 (0.961)	30.4 (1.197)		700	BC
			6.60 (0.258)	24.0 (0.945)	16.0 (0.630)	7.00 (0.274)	330 (12.99)	24.4 (0.961)	30.4 (1.197)		600	BC
6054	15.2 (0.598)	13.7 (0.539)	4.40 (0.170)	24.0 (0.945)	24.0 (0.945)	4.50 (0.178)	330 (12.99)	24.4 (0.961)	30.4 (1.197)	300	600	BC
			4.80 (0.189)	24.0 (0.945)	24.0 (0.945)	5.50 (0.217)	330 (12.99)	24.4 (0.961)	30.4 (1.197)		500	BC
			6.20 (0.244)	24.0 (0.945)	24.0 (0.945)	6.30 (0.248)	330 (12.99)	24.4 (0.961)	30.4 (1.197)		400	BC
			7.00 (0.274)	24.0 (0.945)	24.0 (0.945)	7.60 (0.299)	330 (12.99)	24.4 (0.961)	30.4 (1.197)		300	BC

Film Chip Capacitors

Mounting and Soldering Recommendations

TEMPERATURE SOLDERING PROFILE

For infrared and vapor phase reflow soldering, the temperature profile below shows the times and the temperatures

operating limits. These capacitors are NOT suitable for wave soldering.

Phase	Temperature (°C) *	Time (s)
Preheating	160 to 180°C max.	180s max.
Soldering	180 to 235°C max.	30s max.

*Temperature at capacitor surface

RECOMMENDED SOLDER PASTE THICKNESS

To allow optimum solderability, the recommended soldering paste thickness is:
 150 to 200 µm for 1206 to 2824
 200 to 300 µm for 4030 to 6054

In case of hand soldering, the temperature of the soldering iron should not be above 250°C. Special care must be taken to avoid touching the capacitor body with the iron tip.

PAD DIMENSIONS

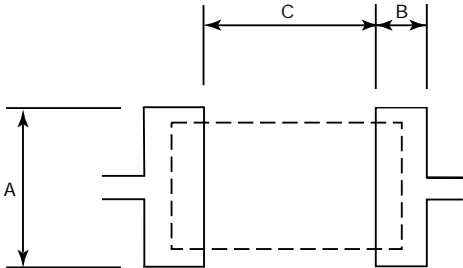

millimeters (inches)

Size Code	Case Size	Dimensions		
		A	B	C
01.21	1206	1.30 (0.051)	1.30 (0.051)	2.20 (0.087)
02.22	1210	2.00 (0.079)	1.30 (0.051)	2.20 (0.087)
03.23	1812	3.00 (0.118)	1.50 (0.059)	3.50 (0.137)
04.24	2220	5.00 (0.195)	1.90 (0.075)	4.50 (0.178)
05.25	2824	6.00 (0.234)	2.50 (0.098)	5.70 (0.224)
16.26	4030	7.50 (0.295)	3.00 (0.118)	8.00 (0.315)
17.27	5040	11.2 (0.441)	3.50 (0.137)	10.3 (0.406)
18.28	6054	14.6 (0.575)	3.60 (0.142)	12.6 (0.496)

RECOMMENDED CLEANING

To clean flux from the PC board assembly, the recommended products are: ethanol, isopropyl alcohol, and deionized water wash. **The cleaning products to avoid are: Toluene, Xylene, Trichloroethylene, Terpene Cleaner EC-7, surface active agent.**

In case of using another solvent, please contact us.

OTHER CAUTIONS

Flame retardancy: the dielectric film is not a flame retardant material.

Environment: contact us when chips are used in humid or gas atmosphere and/or when using with resin.

Recommended handling: do not use edged tools, so not to damage the capacitor.

Film Chip Capacitors



Electrical Properties and Test Conditions

STANDARDIZATION

Reference Standard is CECC 32201 (see detailed tests hereunder)

Test	Description	Performance
Capacitance C	Measurement frequency 1 KHz 20°C	Shall be within tolerance of the rated value
Dissipation Factor DF	Measurement frequency 1 KHz 20°C	DF < 100.10 ⁻⁴
Insulation Resistance IR	Voltage applied: 10 V - for Vr < 100 V - 100 V - for Vr ≥ 100 V -	IR > 1000 MΩ for C ≤ 0.33 μF IR x C > 400 sec. for C > 0.33 μF
Dielectric Strength	Surge Voltage = 1.4 Vr applied for 1 mm between terminals	There shall be no direct breakdown
Mounting	Board = 1.6mm (0.063") thick epoxy glass laminated or alumine substrate	C = within ± 2% of initial value DF = ≤ 100.10 ⁻⁴ at 1 KHz IR = within initial limit
Adhesion	Force of 5 N applied for 10 secs.	No visible damage
Board Bending Test	Bending of 1 mm (0.039") for 90mm (3.543") length	C = within ± 2% of initial value No visible damage
Thermal Shock	500 cycles -55/+105°C	C = within ± 5% of initial value ESR = no more than 3 times initial value IR = not less than 50% of the initial limit
Damp Heat Steady State	40°C 93% RH/no voltage/56 days	C = within ± 7% of initial value Δ DF = < 50.10 ⁻⁴ at 1 KHz IR = not less than 50% of the initial limit
Accelerated Damp Heat (Load Humidity)	85°C 85% RH 1.5V- 500 H	C = within ± 7% of initial value Δ DF = ≤ 70.10 ⁻⁴ at 1 KHz IR = not less than 50% of the initial limit
Life Test	85°C /1.25 Vr/1,000 Hours	C = within ± 8% of initial value Δ DF = < 50.10 ⁻⁴ at 1 KHz IR = not less than 50% of the initial limit
Life Test	105°C / Vr/1,000 Hours 125°C / Vr/1,000 Hours 140°C /0.5 Vr/1,000 Hours	C = within ± 7% of initial value Δ DF = < 50.10 ⁻⁴ at 1 KHz IR = not less than 50% of the initial limit
Charge/Discharge	10,000 cycles/Vr	C = within ± 5% of initial value Δ DF = ≤ 50.10 ⁻⁴ at 1 KHz IR = not less than 50% of the initial limit

Film Chip Capacitors



Electrical and Frequency Characteristics (typical values)

ELECTRICAL CHARACTERISTICS

CAPACITANCE

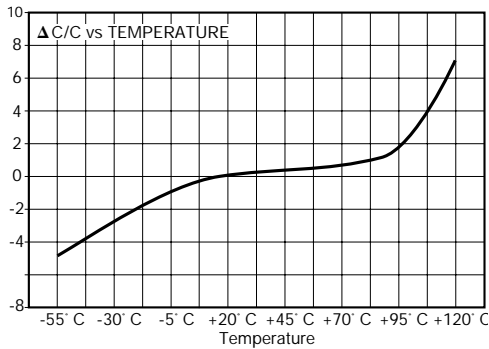

DISSIPATION FACTOR

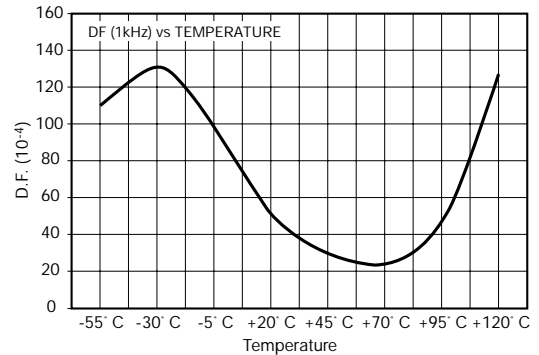

INSULATION RESISTANCE

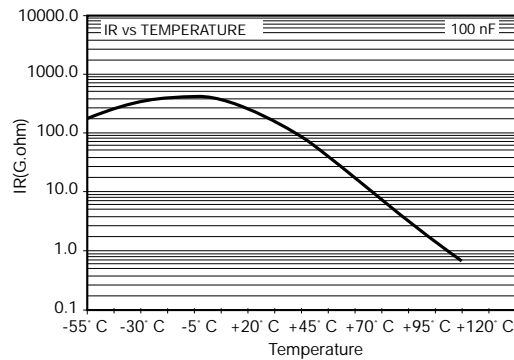

FREQUENCY CHARACTERISTICS

CAPACITANCE

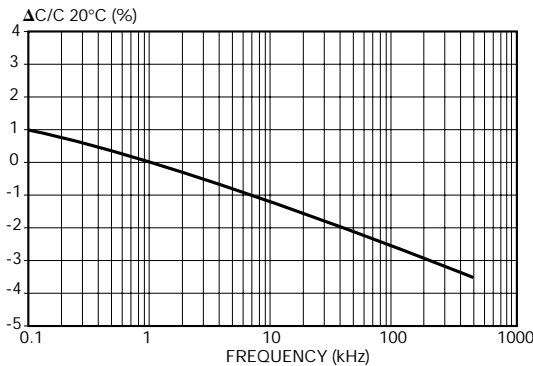

DISSIPATION FACTOR

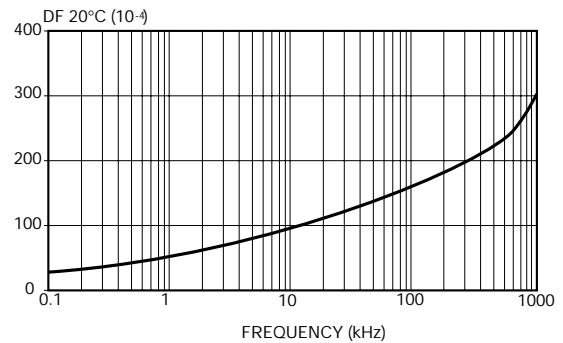

IMPEDANCE

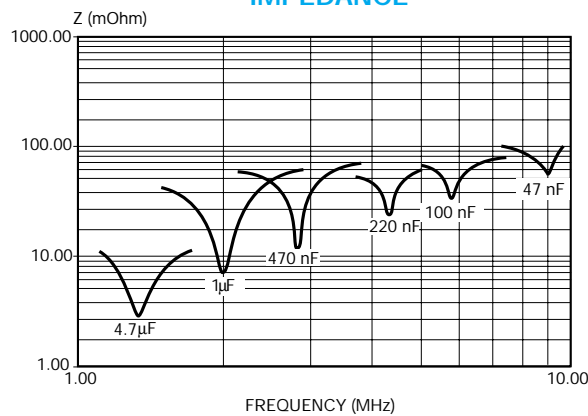

Film Chip Capacitors



Voltage and Frequency Characteristics

MAXIMUM VOLTAGE (V_{rms}) AND CURRENT (I_{rms}) vs FREQUENCY

Typical curves results from measurement carried out at ambient temperature (25°C) and sinusoidal wave-forms (for size CF01 to CF18)

25 VDC / 15 VAC

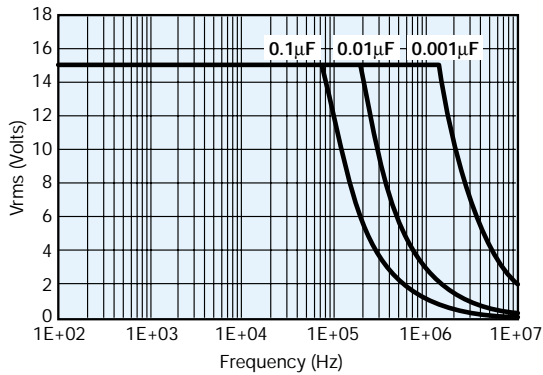

25 VDC / 15 VAC

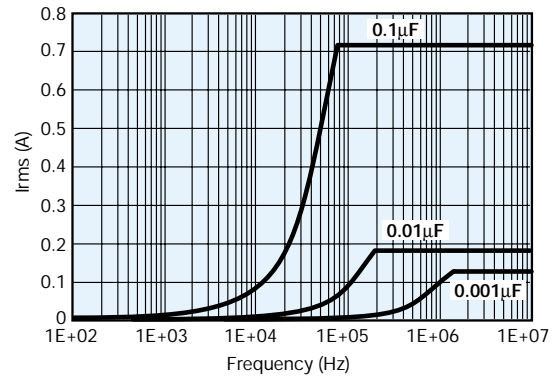

63 VDC / 40 VAC

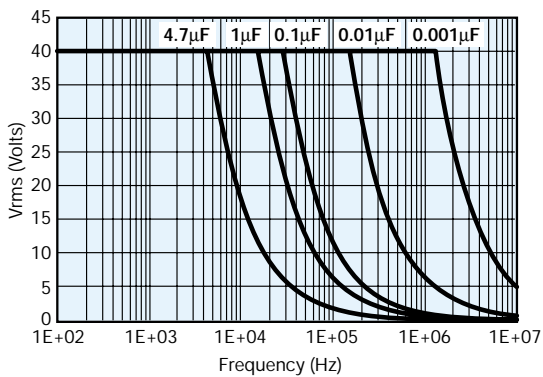

63 VDC / 40 VAC

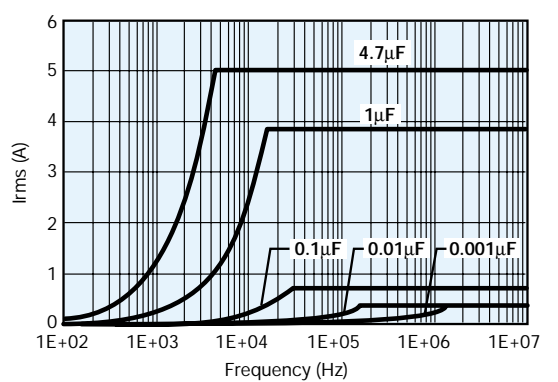

100 VDC / 63 VAC

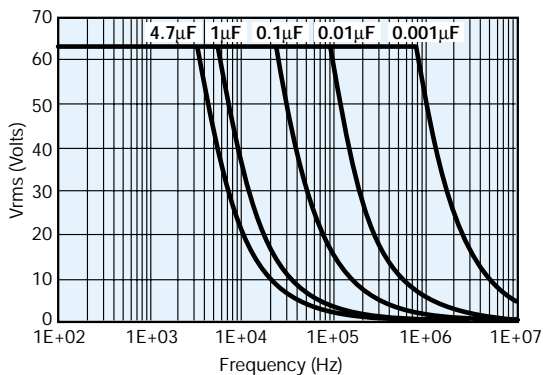

100 VDC / 63 VAC

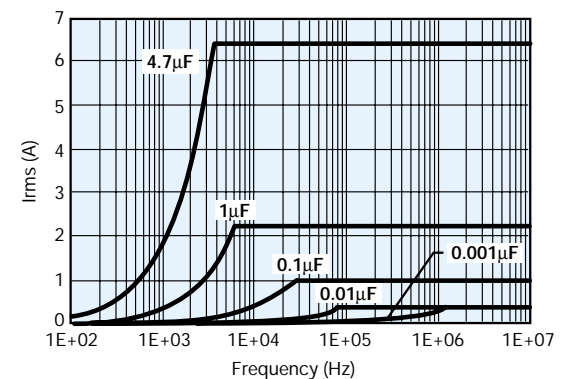

Note: the temperature rise maximum is 40°C

Film Chip Capacitors



Voltage and Frequency Characteristics

MAXIMUM VOLTAGE (V_{rms}) AND CURRENT (I_{rms}) vs FREQUENCY

Typical curves results from measurement carried out at ambient temperature (25°C) and sinusoidal wave-forms (for size CF01 to CF18)

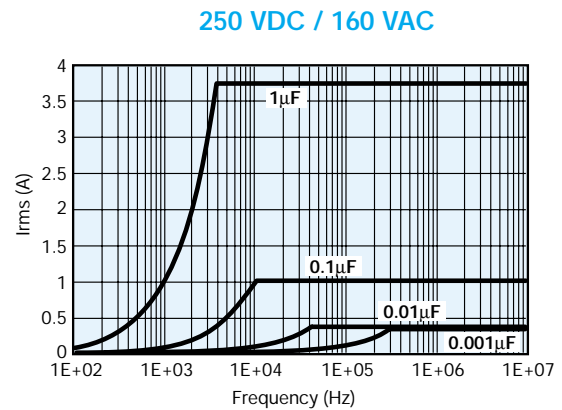
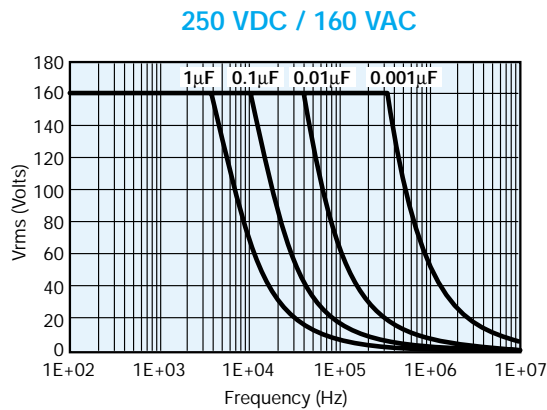
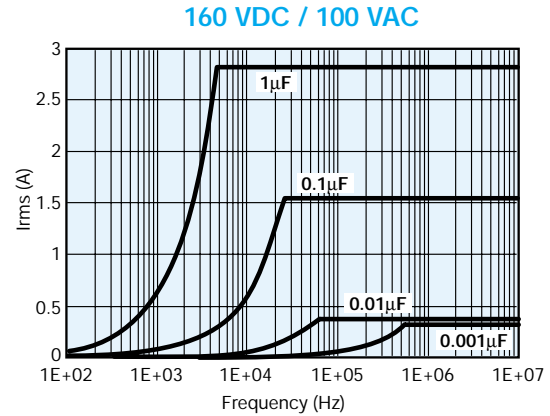
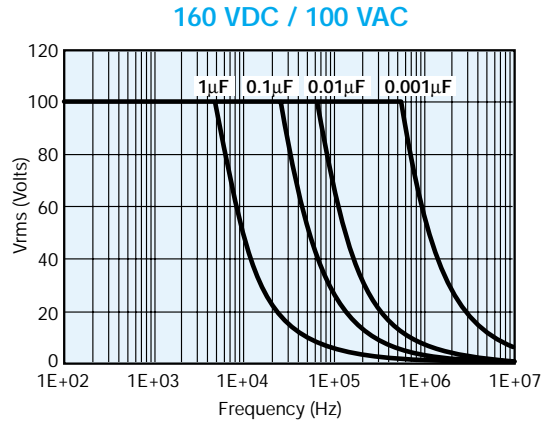

Note: the temperature rise maximum is 40°C

MAXIMUM PULSE RISE TIME (dV/dt)

Voltage Range	25	50/63	100	160	250
dV/dt max (V/ μ sec)	15	40	50	100	150

USA

AVX Myrtle Beach, SC Corporate Offices

Tel: 843-448-9411
FAX: 843-626-5186

AVX Northwest, WA

Tel: 360-669-8746
FAX: 360-699-8751

AVX North Central, IN

Tel: 317-848-7153
FAX: 317-844-9314

AVX Northeast, MA

Tel: 508-485-8114
FAX: 508-485-8471

AVX Mid-Pacific, CA

Tel: 408-436-5400
FAX: 408-437-1500

AVX Southwest, AZ

Tel: 480-539-1496
FAX: 480-539-1501

AVX South Central, TX

Tel: 972-669-1223
FAX: 972-669-2090

AVX Southeast, NC

Tel: 919-878-6357
FAX: 919-878-6462

AVX Canada

Tel: 905-564-8959
FAX: 905-564-9728

EUROPE

AVX Limited, England European Headquarters

Tel: ++44 (0)1252 770000
FAX: ++44 (0)1252 770001

AVX S.A., France

Tel: ++33 (1) 69.18.46.00
FAX: ++33 (1) 69.28.73.87

AVX GmbH, Germany - AVX

Tel: ++49 (0) 8131 9004-0
FAX: ++49 (0) 8131 9004-44

AVX GmbH, Germany - Elco

Tel: ++49 (0) 2741 2990
FAX: ++49 (0) 2741 299133

AVX srl, Italy

Tel: ++390 (0)2 614571
FAX: ++390 (0)2 614 2576

AVX Czech Republic, s.r.o.

Tel: ++420 (0)467 558340
FAX: ++420 (0)467 558345

ASIA-PACIFIC

AVX/Kyocera, Singapore Asia-Pacific Headquarters

Tel: (65) 258-2833
FAX: (65) 350-4880

AVX/Kyocera, Hong Kong

Tel: (852) 2-363-3303
FAX: (852) 2-765-8185

AVX/Kyocera, Korea

Tel: (82) 2-785-6504
FAX: (82) 2-784-5411

AVX/Kyocera, Taiwan

Tel: (886) 2-2696-4636
FAX: (886) 2-2696-4237

AVX/Kyocera, China

Tel: (86) 21-6249-0314-16
FAX: (86) 21-6249-0313

AVX/Kyocera, Malaysia

Tel: (60) 4-228-1190
FAX: (60) 4-228-1196

Elco, Japan

Tel: 045-943-2906/7
FAX: 045-943-2910

Kyocera, Japan - AVX

Tel: (81) 75-604-3426
FAX: (81) 75-604-3425

Kyocera, Japan - KDP

Tel: (81) 75-604-3424
FAX: (81) 75-604-3425

Contact:



<http://www.avxcorp.com>

S-FCC00M1000-C